



Main

Range of product	OsiSense XM
Product or component type	Electronic pressure sensors
Pressure sensor type	Pressure transmitter
Pressure sensor name	XMEP
Electrical circuit type	Control circuit
Pressure sensor size	100 Bar
Local display	Without
Controlled fluid	Fresh water (0...125 °C) Air (-30...125 °C) Hydraulic oil (-30...125 °C)
Fluid connection type	G 1/4A (male) conforming to DIN 3852-E
Electrical connection	1 male connector M12 4 pins
[Us] rated supply voltage	5 V DC SELV (voltage limits: 4.5...5.5 V)
Current consumption	< 7 mA
Type of output signal	Analogue
Analogue output function	0.5...4.5 V, 3-wire
Quantity per set	Set of 1
Type of packing	Individual

Complementary

Pressure setting range	0...100 Bar
Maximum permissible accidental pressure	300 Bar
Destruction pressure	600 Bar
Materials in contact with fluid	Fluorocarbon FPM Stainless steel AISI 316L
Operating position	Any position
Protection type	Reverse polarity Load short-circuit
Electromagnetic compatibility	Electrostatic discharge immunity test conforming to ISO 10605 criteria A 15 kV air, 15 kV contact Susceptibility to electromagnetic fields conforming to ISO 11452-2 criteria A 100 V/m 200...2000 MHz Susceptibility to electromagnetic fields conforming to ISO 11452-4 criteria A 100 mA 20...400 MHz Susceptibility to conducted disturbances conforming to EN/IEC 61000-4-6 criteria A 30 V 0.15...80 MHz Electrical fast transient/burst immunity test conforming to EN/IEC 61000-4-4 criteria A 4 kV Susceptibility to conducted transient disturbances conforming to ISO 7637-2 criteria B level 3

[Uimp] rated impulse withstand voltage	0.5 KV
Response time on output	<= 2 ms 10...90 % of full scale
Measurement accuracy	+/- 0.5 % of the measuring range
Accuracy	0.1 % of the measuring range
Drift of the sensitivity	+/- 0.02 % of measuring range/°K
Drift of the zero point	+/- 0.02 % of measuring range/°K
Repeat accuracy	+/- 0.5 % of the measuring range
Mechanical durability	10000000 Cycles
Net weight	0.095 Kg
Diameter	26 Mm
Length	38.1 Mm

Environment

Standards	EN 13309 ISO 14982 UL 61010-1 EN/IEC 61326-2-3 ECE 10R-5 ISO 13766
Product certifications	CE CULus E2
Ambient air temperature for operation	-40...100 °C
Ambient air temperature for storage	-50...100 °C
Vibration resistance	12 gn sinus (f = 20...520 Hz)test 4 conforming to ISO 16750-3 18 gn random (f = 10...2000 Hz)test 4 conforming to ISO 16750-3
Shock resistance	50 gn for 11 ms conforming to EN/IEC 60068-2-27
IP degree of protection	IP65 conforming to EN/IEC 60529 IP67 conforming to EN/IEC 60529 IP69K conforming to EN/IEC 60529

Packing Units

Unit Type of Package 1	PCE
Number of Units in Package 1	1
Package 1 Weight	94 G
Package 1 Height	4.1 Cm
Package 1 width	4.5 Cm
Package 1 Length	8.5 Cm
Unit Type of Package 2	S01
Number of Units in Package 2	24
Package 2 Weight	2.457 Kg
Package 2 Height	15 Cm
Package 2 width	15 Cm
Package 2 Length	40 Cm

Offer Sustainability

Sustainable offer status	Green Premium product
REACH Regulation	REACH Declaration
EU RoHS Directive	Pro-active compliance (Product out of EU RoHS legal scope) EU RoHS Declaration
Mercury free	Yes
RoHS exemption information	Yes
Environmental Disclosure	Product Environmental Profile

Contractual warranty

Warranty	18 months
----------	-----------

Dimensions

mm
in.

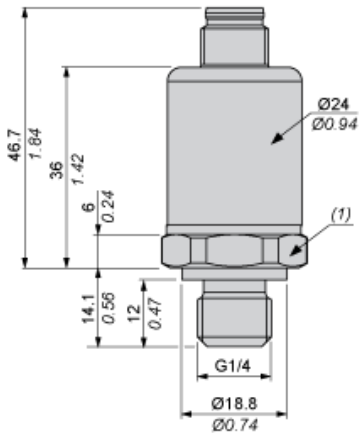

(1) SW24, tightening torque # 24 N-m / 212 lb-in

Connections and Schema

Connector Wiring

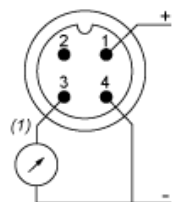

(1) V out
Pin 2 Not connected

Performance Curves

Curves

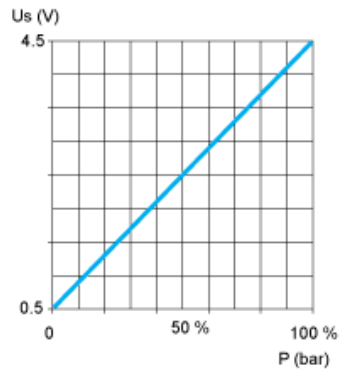

Product Life Status : Commercialised
