



Main

Range of product	Harmony ST6 & STW6
Product or component type	Touch panel screen
Software designation	Web interface for operator
Processor name	ARM Cortex-A8

Complementary

Display size	15 inch
Display type	Colour TFT LCD
Display colour	16 million colours
Display resolution	1366 x 768 pixels FWXGA
Touch panel	Single touch analogue resistive
Backlight lifespan	50000 hours with white
Brightness	16 levels
Character font	ASCII ASCII (European characters) Katakana
[Us] rated supply voltage	24 V DC +/- 20 %
Inrush current	30 A
Local signalling	Status LED green, steady for offline Status LED green, steady for operating Status LED green, flashing for operating Status LED green, faded for stand-by Status LED orange, flashing for software starting up Status LED red, steady for power supply (ON) Status LED red, flashing for operating Status LED red, off for power supply (OFF)
Power consumption in W	18.5 W
Processor frequency	800 MHz
Port Ethernet	10/100BASE
Memory description	Device memory 512 MB Backup memory 512 MB User data memory 128 kB
Integrated connection type	1 USB 2.0 type Aback 1 USB 2.0 type micro Bback

Disclaimer: This documentation is not intended as a substitute for and is not to be used for determining suitability or reliability of these products for specific user applications

	2 Ethernet - female RJ45bottom
Supply	External supply
Realtime clock	Built-in 0...50 °C Built-in 10...90 % RH
Fixing mode	By 6 screws, mounting on 1.6...5 mm thick panel conforming to UL 61010-2-201 By 6 screws conforming to EN 61131-2 By 6 screws conforming to IEC 61000-6-2
Enclosure material	PC
Front material	Aluminium
Marking	CE
Cut-out dimensions	394 x 250 mm panel cut dimension
Height	268 mm
Width	412 mm
Depth	50 mm
Net weight	2.7 kg

Environment

Immunity to microbreaks	10 ms
Standards	EN 61000-6-4 EN 61000-6-2 EN 61131-2 UL 61010-2-201 CSA C22.2 No 61010-2-201
Product certifications	CSA CE China RoHS REACH
Directives	2014/35/EU - low voltage directive 2014/30/EU - electromagnetic compatibility
Ambient air temperature for operation	0...50 °C
Ambient air temperature for storage	-20...60 °C
Relative humidity	10...90 % non-condensing
Operating altitude	2000 m
IP degree of protection	IP20 (rear panel) conforming to IEC 61131-2 IP65 (front panel) conforming to IEC 61131-2
NEMA degree of protection	NEMA 4 front panel (indoor use) NEMA 13 front panel (in enclosure)
Shock resistance	147 m/s ² for 11 ms (X, Y, Z directions for 3 times) conforming to EN/IEC 61131-2
Vibration resistance	+/- 3.5 mm (f = 5...9 Hz)X, Y, Z directions for 10 cycles (approx. 100 min) conforming to EN/IEC 61131-2 9.8 m/s ² (f = 9...150 Hz)
Electromagnetic compatibility	Electrical fast transient/burst immunity test - test level: 2 kV (power ports) conforming to IEC 61000-4-4 Electrical fast transient/burst immunity test - test level: 1 kV (signal ports) Electrostatic discharge immunity test - test level: 6 kV (contact discharge) conforming to EN/IEC 61000-4-2 level 3 Electrostatic discharge immunity test - test level: 8 kV (air discharge)

Offer Sustainability

EU RoHS Directive	Compliant EU RoHS Declaration
Mercury free	Yes
RoHS exemption information	Yes
China RoHS Regulation	China RoHS declaration
WEEE	The product must be disposed on European Union markets following specific waste collection and never end up in rubbish bins

Dimensions

External Dimensions

mm
in.



(3)

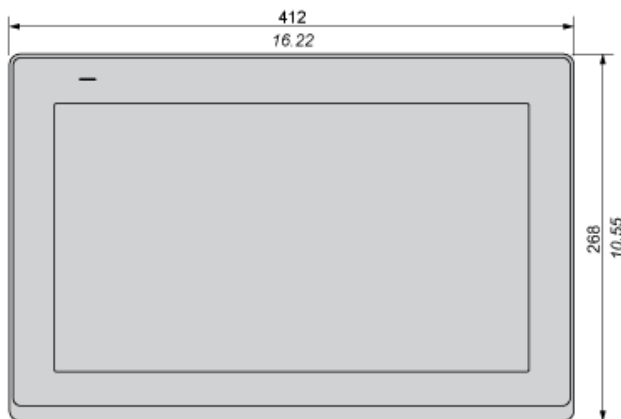

(1)



(2)

- (1) : Front
- (2) : Left
- (3) : Bottom

Dimensions with Installation Fasteners

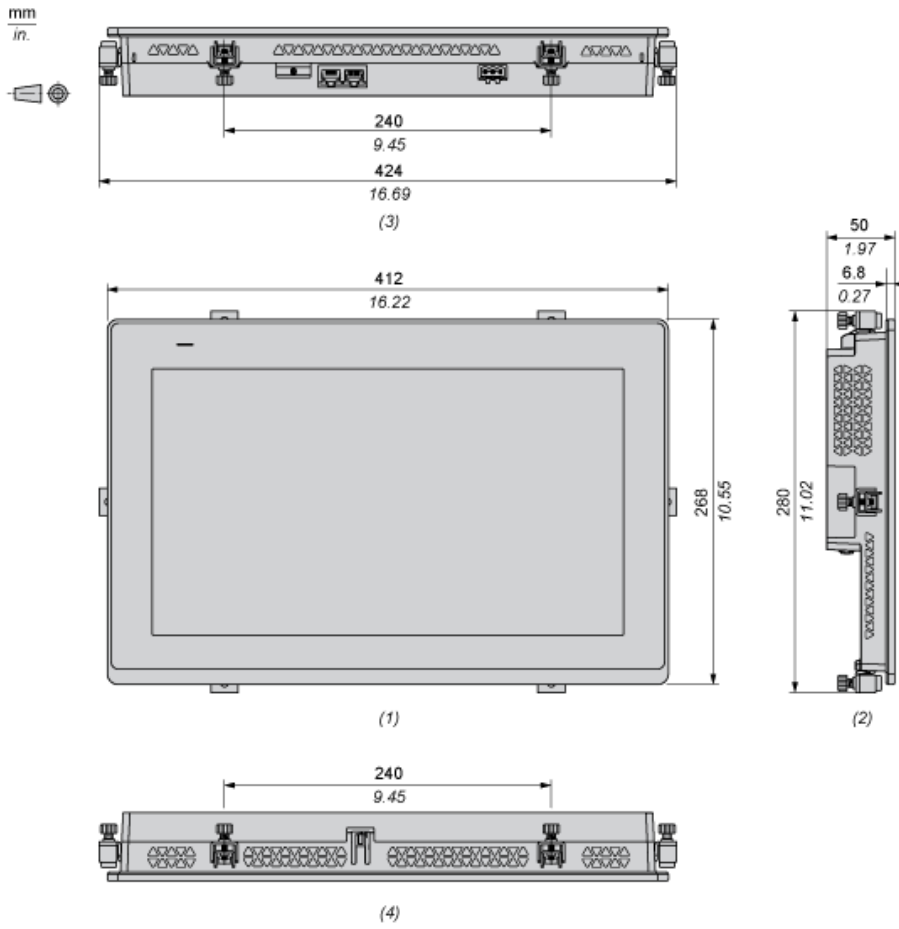

- (1) : Front
- (2) : Left
- (3) : Bottom
- (4) : Top

Dimensions with Cables

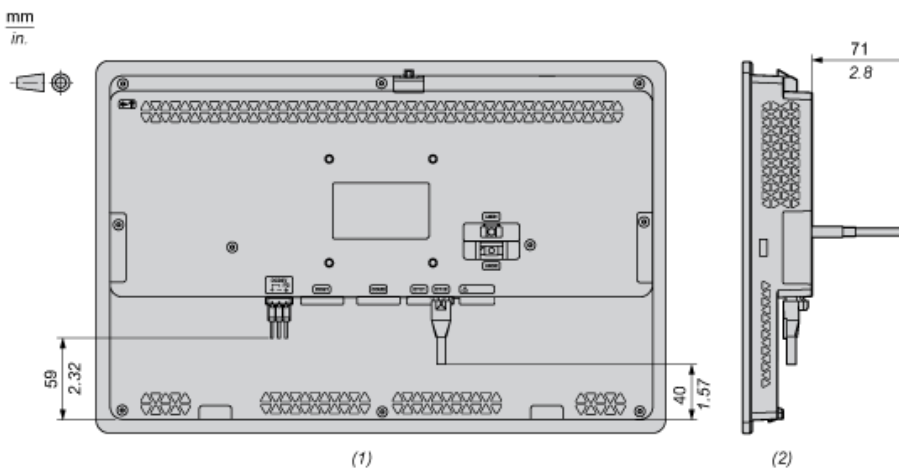

- (1) : Rear
- (2) : Right

Mounting

Panel Cut Dimensions

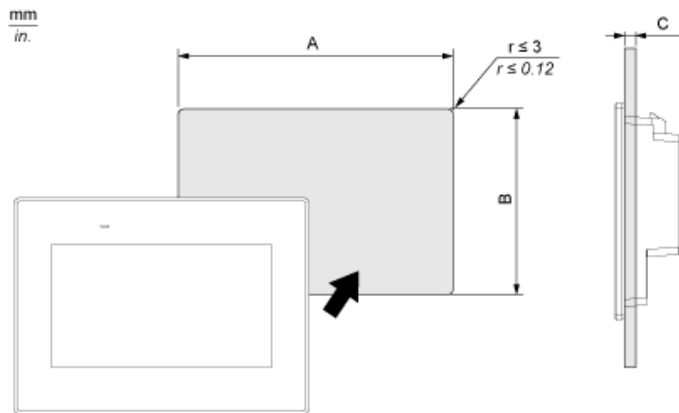

A		B		C	
mm	in.	mm	in.	mm	in.
394 (+1, -0)	15.51 (+0.04, -0)	250 (+1, -0)	9.84 (+0.04, -0)	1.6...5	0.06...0.2

Installation Requirements

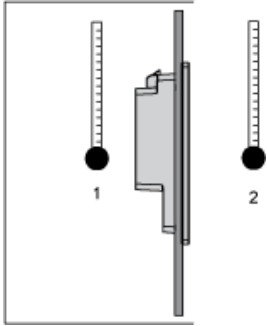

- 1: Internal temperature
- 2: External temperature

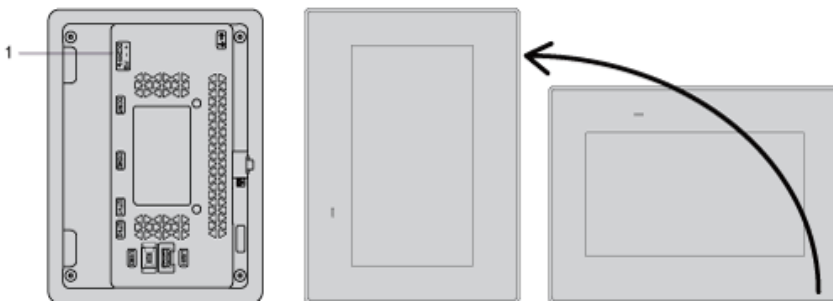

- 1: Power connector

Mounting Angle

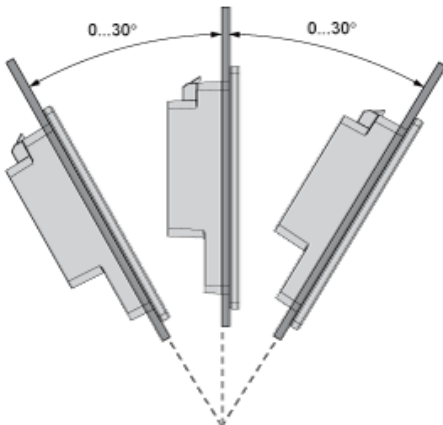

Clearance

mm
in.

