



GT1455-QTBD(E), GT1450-QMBD(E)  
GT1450-QLBD(E)

GT14 General Description



Manual Number	JY997D43901G
Date	Oct. 2016

This manual describes the part names, dimensions, mounting, and specifications of the product. Before use, read this manual and manuals of relevant products fully to acquire proficiency in handling and operating the product. Make sure to learn all the product information, safety information, and precautions.

And, store this manual in a safe place so that you can take it out and read it whenever necessary. Always forward it to the end user.

Registration  
Ethernet is a trademark of Xerox Corporation in the United States. The company name and the product name to be described in this manual are the registered trademarks or trademarks of each company.

Effective Oct. 2016  
Specifications are subject to change without notice.

© 2011 MITSUBISHI ELECTRIC CORPORATION

**Safety Precaution** (Read these precautions before using.)

Before using this product, please read this manual and the relevant manuals introduced in this manual carefully and pay full attention to safety to handle the product correctly.

The precautions given in this manual are concerned with this product. In this manual, the safety precautions are ranked as "WARNING" and "CAUTION".



Indicates that incorrect handling may cause hazardous conditions, resulting in death or severe injury.



Indicates that incorrect handling may cause hazardous conditions, resulting in medium or slight personal injury or physical damage.

Depending on circumstances, procedures indicated by "CAUTION" may also be linked to serious results.

In any case, it is important to follow the directions for usage.

**DESIGN PRECAUTIONS**  **WARNING**

- Some failures of the GOT or cable may keep the outputs on or off. An external monitoring circuit should be provided to check for output signals which may lead to a serious accident. Not doing so can cause an accident due to false output or malfunction.
- If a communication fault (including cable disconnection) occurs during monitoring on the GOT, communication between the GOT and PLC CPU is suspended and the GOT becomes inoperative. A system where the GOT is used should be configured to perform any significant operation to the system by using the switches of a device other than the GOT on the assumption that a GOT communication fault will occur. Not doing so can cause an accident due to false output or malfunction.
- Do not use the GOT as the warning device that may cause a serious accident. An independent and redundant hardware or mechanical interlock is required to configure the device that displays and outputs serious warning. Failure to observe this instruction may result in an accident due to incorrect output or malfunction.
- Incorrect operation of the touch switch(s) may lead to a serious accident if the GOT backlight is gone out. When the GOT backlight goes out, the POWER LED flickers (green/orange) and the display section turns black and causes the monitor screen to appear blank, while the input of the touch switch(s) remains active. This may confuse an operator in thinking that the GOT is in "screensaver" mode, who then tries to release the GOT from this mode by touching the display section, which may cause a touch switch to operate. Note that the following occurs on the GOT when the backlight goes out.
  - The POWER LED flickers (green/orange) and the monitor screen appears blank
- The display section is an analog-resistive type touch panel. If you touch the display section simultaneously in 2 points or more, the switch that is located around the center of the touched point, if any, may operate. Do not touch the display section in 2 points or more simultaneously. Doing so may cause an accident due to incorrect output or malfunction.
- When programs or parameters of the controller (such as a PLC) that is monitored by the GOT are changed, be sure to reset the GOT or shut off the power of the GOT at the same time. Not doing so can cause an accident due to false output or malfunction.

**DESIGN PRECAUTIONS**  **WARNING**

- When the security of the GOT and relevant information need to be protected against illegal access from an external device via the Internet, take measures at the user's discretion. Failure to do so may cause the configured information to be read out illegally.

**DESIGN PRECAUTIONS**  **CAUTION**

- Do not bundle the control and communication cables with main-circuit, power or other wiring. Run the above cables separately from such wiring and keep them a minimum of 100mm (3.94in.) apart. Not doing so may cause a malfunction.
- Do not press the GOT display section with a pointed material as a pen or driver. Doing so can result in a damage or failure of the display section.
- When using the GOT with Ethernet connection, available IP addresses are restricted depending on the system configuration.
  - When connecting two or more GOT units to the Ethernet network: Do not specify the IP address "192.168.0.18" to the GOT or any connected equipment.
  - When connecting one GOT unit to the Ethernet network: Do not specify the IP address "192.168.0.18" to any connected equipment other than the GOT. If the IP address "192.168.0.18" is specified in the above system configuration, IP address overlap occurs when the GOT is started up, and adverse effect may be given to communication in the equipment in which the IP address "192.168.0.18" is set. Operation executed at IP address overlap varies depending on the equipment and system.
- Turn on the power of the connected equipment and network equipment, and make them ready for communication before connecting them to the GOT. If the connected equipment and network equipment are not ready for communication, a communication error may occur in the GOT.

**MOUNTING PRECAUTIONS**  **WARNING**

- Be sure to shut off all phases of the external power supply used by the system before mounting or removing the GOT to/from the panel. Not doing so can cause the unit to fail or malfunction.

**MOUNTING PRECAUTIONS**  **CAUTION**

- Use the GOT in the environment that satisfies the general specifications described in this manual. Not doing so can cause an electric shock, fire, malfunction or product damage or deterioration.
- When mounting the GOT to the control panel, tighten the mounting screws in the specified torque range. Undertightening can cause the GOT to drop, short circuit or malfunction, and deteriorate the waterproof effect and oilproof effect. Overtightening can cause a drop, short circuit or malfunction due to the damage of the screws or the GOT, and deteriorate the waterproof effect and oilproof effect due to distortion of the protective cover for oil, GOT or panel.
- Never drop cutting chips and electric wire chips into the ventilation window of the GOT when you drill screw holes or perform wiring. Otherwise, fire, failure or malfunction may be caused.
- When inserting/removing a SD card into/from the GOT, turn the SD card access switch off in advance. Failure to do so may corrupt data within the SD card.
- When removing a SD card from the GOT, make sure to support the SD card by hand, as it may pop out. Failure to do so may cause the SD card to drop from the GOT and break.
- When installing a USB memory to the GOT, make sure to install the USB memory to the USB interface firmly. Failure to do so may cause a malfunction due to poor contact.
- Before removing the USB memory from the GOT, operate the utility screen for removal. After the successful completion dialog box is displayed, remove the memory by hand carefully. Failure to do so may cause the USB memory to drop, resulting in a damage or failure of the memory.
- Operate and store the GOT in environments without direct sunlight, high temperature, dust, humidity, and vibrations.
- When using the GOT in the environment of oil or chemicals, use the protective cover for oil. Failure to do so may cause failure or malfunction due to the oil or chemical entering into the GOT.

**WIRING PRECAUTIONS**  **WARNING**

- Be sure to shut off all phases of the external power supply used by the system before wiring. Failure to do so may result in an electric shock, product damage or malfunctions.
- Please make sure to ground FG terminal of the GOT power supply section by applying 100 or less which is used exclusively for the GOT. Not doing so may cause an electric shock or malfunction.

**WIRING PRECAUTIONS**  **WARNING**

- Correctly wire the GOT power supply section after confirming the rated voltage and terminal arrangement of the product. Not doing so can cause a fire or failure.
- Tighten the terminal screws of the GOT power supply section in the specified torque range. Undertightening can cause a short circuit or malfunction. Overtightening can cause a short circuit or malfunction due to the damage of the screws or the GOT.
- Exercise care to avoid foreign matter such as chips and wire cutoffs entering the GOT. Not doing so can cause a fire, failure or malfunction.

**WIRING PRECAUTIONS**  **CAUTION**

- The cables connected to the unit must be run in ducts or clamped. Not doing so can cause the unit or cable to be damaged due to the dangling, motion or accidental pulling of the cables or can cause a malfunction due to a cable connection fault.
- When unplugging the cable connected to the unit, do not hold and pull the cable portion. Doing so can cause the unit or cable to be damaged or can cause a malfunction due to a cable connection fault.
- Plug the communication cable into the connector of the connected unit and tighten the mounting and terminal screws in the specified torque range. Undertightening can cause a short circuit or malfunction due to the damage of the screws or unit.

**TEST OPERATION PRECAUTIONS**  **WARNING**

- Before performing the test operations of the user creation monitor screen (such as turning ON or OFF bit device, changing the word device current value, changing the settings or current values of the timer or counter, and changing the buffer memory current value), read through the manual carefully and make yourself familiar with the operation method. During test operation, never change the data of the devices which are used to perform significant operation for the system. False output or malfunction can cause an accident.

**STARTUP/MAINTENANCE PRECAUTIONS**  **WARNING**

- When power is on, do not touch the terminals. Doing so can cause an electric shock or malfunction.
- Connect the battery correctly. Do not discharge, disassemble, heat, short, solder or throw the battery into the fire. Incorrect handling may cause the battery to generate heat, burst or take fire, resulting in injuries or fires.
- Before starting cleaning or terminal screw retightening, always switch off the power externally in all phases. Not switching the power off in all phases can cause a unit failure or malfunction. Undertightening can cause a short circuit or malfunction. Overtightening can cause a short circuit or malfunction due to the damage of the screws or unit.

**STARTUP/MAINTENANCE PRECAUTIONS**  **CAUTION**

- Do not disassemble or modify the unit. Doing so can cause a failure, malfunction, injury or fire.
- Do not touch the conductive and electronic parts of the unit directly. Doing so can cause a unit malfunction or failure.
- The cables connected to the unit must be run in ducts or clamped. Not doing so can cause the unit or cable to be damaged due to the dangling, motion or accidental pulling of the cables or can cause a malfunction due to a cable connection fault.
- When unplugging the cable connected to the unit, do not hold and pull the cable portion. Doing so can cause the unit or cable to be damaged or can cause a malfunction due to a cable connection fault.
- Do not drop or apply any impact to the battery. If any impact has been applied, discard the battery and never use it. The battery may be damaged by the drop or impact.
- Before touching the unit, always touch grounded metal, etc. to discharge static electricity from human body, etc. Not doing so can cause the unit to fail or malfunction.
- Replace battery with GT11-50BAT by Mitsubishi electric Co. only. Use of another battery may present a risk of fire or explosion.
- Dispose of used battery promptly. Keep away from children. Do not disassemble and do not dispose of in fire.

**DISPOSAL PRECAUTIONS**  **CAUTION**

- When disposing of the product, handle it as industrial waste.
- When disposing of batteries, separate them from other wastes according to the local regulations. (For details of the battery directive in EU member states, refer GOT User's Manual.)

**TOUCH PANEL PRECAUTIONS**  **CAUTION**

- For the analog-resistive film type touch panels, normally the adjustment is not required. However, the difference between a touched position and the object position may occur as the period of use elapses. When any difference between a touched position and the object position occurs, execute the touch panel calibration.
- When any difference between a touched position and the object position occurs, other object may be activated. This may cause an unexpected operation due to incorrect output or malfunction.

**TRANSPORTATION PRECAUTIONS**  **CAUTION**

- When transporting lithium batteries, make sure to treat them based on the transport regulations. (Refer to User's Manual for details of the regulated models.)
- Before transporting the GOT, turn the GOT power on and check that the battery voltage status is normal on the Time setting & display screen (utilities screen). In addition, confirm that the adequate battery life remains on the rating plate. Transporting the GOT with the low battery voltage or the battery the reached battery life may destabilize the backup data unstable during transportation.
- Make sure to transport the GOT main unit and/or relevant unit(s) in the manner they will not be exposed to the impact exceeding the impact resistance described in the general specifications of this manual, as they are precision devices. Failure to do so may cause the unit to fail. Check if the unit operates correctly after transportation.

**Associated Manuals**

The following manuals are relevant to this product. When these loose manuals are required, please consult with our local distributor.

Manual name	Contents	Manual Number (Model Code)
GT14 User's Manual (sold separately)	Describes the GT14 hardware-relevant content such as part names, external dimensions, mounting, power supply wiring, specifications, and introduction to option devices	JY997D44801 (09R823)
GT Designer3 Version1 Screen Design Manual (For GOT1000 Series) (Fundamentals) 1/2, 2/2 (sold separately) *1	Describes methods of the GT Designer3 installation operation, basic operation for drawing and transmitting data to GOT1000 series	SH-080866ENG (1D7MB9)
GT Designer3 Version1 Screen Design Manual (For GOT1000 Series) (Functions) 1/2, 2/2 (sold separately) *1	Describes specifications and settings of the object functions used in GT Designer3	SH-080867ENG (1D7MC1)

\*1 Stored in the GT Works3/GT Designer3 in PDF format.

For details of a PLC to be connected, refer to the PLC user's manual respectively.

**Bundled Items**

Product Name	Model Name	Specifications
GOT	GT1455-QTBD	5.7" diagonal [320 × 240 dots], TFT color (65536 colors), built-in battery and Ethernet interface
	GT1455-QTBD	5.7" diagonal [320 × 240 dots], TFT color (65536 colors), built-in battery
	GT1450-QMBDE	5.7" diagonal [320 × 240 dots], TFT monochrome (black/white), built-in battery and Ethernet interface
	GT1450-QMBD	5.7" diagonal [320 × 240 dots], TFT monochrome (black/white), built-in battery
	GT1450-QLBDE	5.7" diagonal [320 × 240 dots], STN monochrome (black/white), built-in battery and Ethernet interface
	GT1450-QLBD	5.7" diagonal [320 × 240 dots], STN monochrome (black/white), built-in battery

Bundled item	Quantity
Mounting brackets	4
Mounting screws: M4 x 35mm (1.38")	4
Dust-/Water-proof packing	1
GT14 General Description (This manual)	1

## 1. Features

- Improved monitoring performance and connectivity to FA devices
  - Multiple languages are displayed using the Unicode2.1-compatible fonts and beautiful characters are drawn using the TrueType and high quality fonts.
  - Two types of display modes are provided: 65536-colors display and monochrome display.
  - In the monochrome display, 16 scales are used to improve the display. A fine and beautiful full-color display which shows even small characters clearly, is enabled by adopting the high intensity, wide viewing angle and high definition TFT color LCD. (Also compatible with digital screen displays with 65536 colors, BMP, etc.)
  - High-speed monitoring through high-speed serial communication at 115.2 kbps maximum or through Ethernet connection.
  - High speed display and high speed touch switch response.
- More efficient GOT operations including screen design, startup, adjustment, management and maintenance works
  - The 9MB built-in flash memory is included as standard.
  - SD card interface is included as standard.
  - RS-232 interface is included as standard.
  - RS-422/485 interface is included as standard.
  - USB interface (host/device) are included as standard.
  - Ethernet interface is included. (in some models)
- Enhanced support of FA setup tools
  - PLC program transfer and monitoring are possible via the personal computer that is connected to the GOT if connected directly to the A, QnA, L, Q, or FX series of the PLC CPU (FA transparent function).

## 2. Part Name

### 2.1 Front

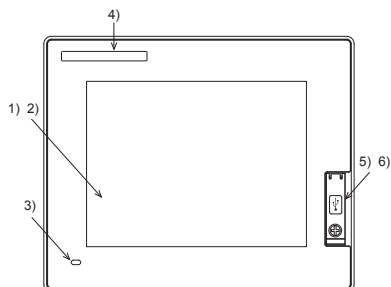

No	Name	Specifications
1)	Display screen	Displays the utility screen and the user creation screen. GT1455-QTBD(E):320x240 dots, TFT color liquid crystal GT1450-QMBD(E):320x240 dots, TFT monochrome (white/black) liquid crystal, 16 scales GT1450-QLBD(E):320x240 dots, STN monochrome (white/black) liquid crystal, 16 scales
2)	Touch panel	For operating the touch switches in the utility screen and the user creation screen
3)	POWER LED	Lit in green: Power is correctly supplied Lit in orange: Screen saving Blinking in orange/green: Blown backlight bulb Not lit: Power is not supplied
4)	Logo label	Removable
5)	USB interface	USB interface for connecting a personal computer (Device) OS installation, project data download, FA transparent
6)	USB environmental protection cover	Opens/Closes when the USB interface is used.

For the PC connection, refer to the following.

→ GT14 User's Manual

### 2.2 Back/Bottom

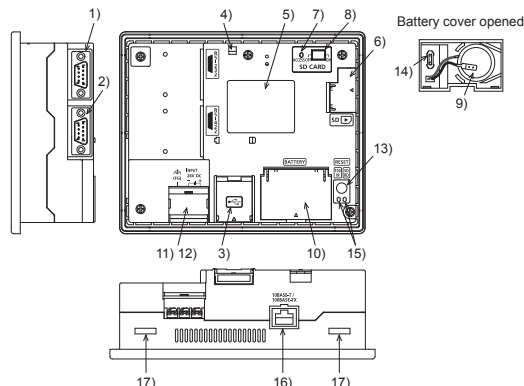

No.	Name	Specifications
1)	RS-232 interface	For communicating with controller or personal computer (D-sub 9-pin male)
2)	RS-422/485 interface	For communicating with controller (D-sub 9-pin female)
3)	USB interface	For data transfer, data storage USB interface (Host)
4)	Hole for preventing USB cable disconnection	Hole for fixing the USB cable with a cable tie (such as Insulock) to prevent disconnection
5)	Rating plate (nameplate)	--
6)	SD card interface	Interface for installing the SD card to GOT
7)	SD card access LED	Lit: SD card accessed Not lit: SD card not accessed
8)	SD card access switch	Switch for prohibiting access to SD card before removing the SD card from the GOT ON: SD card being accessed (SD card removal prohibited) OFF: No access to SD card (SD card removal possible)
9)	Battery	GT11-50BAT battery for storing clock data, alarm history and recipe data
10)	Battery cover	Open or close when replacing the battery. Opened and closed when the terminating resistor is changed over
11)	Power terminal	Power terminal and FG terminal (for power supply (24VDC) to GOT and grounding)
12)	Power terminal cover	Open or close when connecting a power terminal. (Color: transparent)
13)	Reset switch	Hardware reset switch (Use an isolated rod to operate.)
14)	Terminating resistor selector switch	Terminating resistor selector switch of RS-422/485 (330Ω/OPEN/110Ω)
15)	Ethernet communication status LED	SD RD: Turns on in green during data communication, 100M: Turns on in green during 100Mbps transmission.
16)	Ethernet interface	For connecting the equipment through Ethernet (RJ-45 connector)
17)	Hole for unit installation fitting	Hole for the inserting installation fittings (accessory) during the GOT installation to the panel (4 holes at top and bottom)

For the connection to the controller (PLC, microcomputer board, bar code reader, RFID, etc) or PC, refer to the following.

→ GT14 User's Manual

## 3. Specifications

### 3.1 General Specifications

Item	Specifications					
Operating ambient temperature	Display section	0 to 50°C				
	Other than display section	0 to 55°C (When mounted horizontally), 0 to 50°C (When mounted vertically)				
Storage ambient temperature	-20 to 60°C					
Operating ambient humidity	10 to 90% RH, non-condensing (STN liquid crystal type to be stored at or below 39°C WBT.)					
Storage ambient humidity	10 to 90% RH, non-condensing (STN liquid crystal type to be stored at or below 39°C WBT.)					
Vibration resistance	Conforms to JIS B3502 and IEC61131-2	Under intermittent vibration	Frequency	Acceleration	Half-amplitude	Sweep Count 10 times each in X, Y and Z directions
			5 to 8.4Hz	--	3.5mm	
		Under continuous vibration	8.4 to 150Hz	9.8m/s <sup>2</sup>	--	
			5 to 8.4Hz	--	1.75mm	
			8.4 to 150Hz	4.9m/s <sup>2</sup>	--	
Shock resistance	Conforms to JIS B3502, IEC 61131-2 (147 m/s <sup>2</sup> , 3 times each in X, Y and Z directions)					
Operating atmosphere	Must be free of lamp black, corrosive gas, flammable gas, or excessive amount of electro conductive dust particles and must be no direct sunlight. (Same as for saving)					
Operating altitude <sup>1)</sup>	2000 m (6562 ft) max.					
Installation location	Inside control panel					
Overvoltage category <sup>2)</sup>	II or less					
Pollution degree <sup>3)</sup>	2 or less					
Cooling method	Self-cooling					

<sup>1)</sup> Do not use or store the GOT under pressure higher than the atmospheric pressure of altitude 0m (0ft.). Failure to observe this instruction may cause a malfunction. When the air inside the control panel is purged by pressurization, the surface sheet may be lifted by high pressure. As a result, the touch panel may be difficult to press, and the sheet may be peeled off.

<sup>2)</sup> This indicates the section of the power supply to which the equipment is assumed to be connected between the public electrical power distribution network and the machinery within the premises. Category II applies to equipment for which electrical power is supplied from fixed facilities. The surge voltage withstand level for up to the rated voltage of 300 V is 2500 V.

<sup>3)</sup> This index indicates the degree to which conductive material is generated in the environment where the equipment is used. In pollution degree 2, only non-conductive pollution occurs but temporary conductivity may be produced due to condensation.

### 3.2 Performance Specifications

Item	Specifications			
	GT1455-QTBD(E)	GT1450-QMBD(E)	GT1450-QLBD(E)	
Display section <sup>1)</sup>	Type	TFT color liquid crystal	TFT monochrome (white/black) liquid crystal	STN monochrome (white/black) liquid crystal
	Screen size	5.7"		
	Resolution	320 × 240 dots		
	Display size	W115(4.53) × H86(3.39)[mm](inch) (Horizontal format)		
	Display character	16-dot standard font: 20 characters × 15 lines, 12-dot standard font: 26 characters × 20 lines		
	Display color	65536 colors	Monochrome (white/black), 16 scales	
	Display angle <sup>2)</sup>	Left/Right: 80 degrees, Top: 80 degrees, Bottom: 60 degrees (Horizontal format)		Left/Right: 45 degrees, Top: 20 degrees, Bottom: 40 degrees (Horizontal format)
	Contrast adjustment	--		32-level adjustment
	Intensity of LCD only	400[cd/m <sup>2</sup> ]	300[cd/m <sup>2</sup> ]	
	Intensity adjustment	8-level adjustment		
Life	Approx. 50,000h. (Time for display intensity to become 1/5 at operating ambient temperature of 25°C)			
Backlight	LED (irreplaceable by a user) Backlight off/screen saving time can be set. <sup>3)</sup>			
Touch panel <sup>4)</sup>	Life	Approx. 70,000h or longer (Time for display intensity reaches 50% at the operating ambient temperature of 25°C)		
	Type	Analog resistive film touch panel		
	Key size	Minimum 2 × 2 dots (per key)		
	Number of points touched simultaneously	Simultaneous presses not allowed. (Only 1 point can be touched.)		
Memory	Life	1 million times or more (operating force 0.98N max.)		
	C drive <sup>5)</sup>	Flash memory (Internal), for storing project data (9Mbytes) and OS		
	Life (Number of write times)	100,000 times		
Battery	D drive	SRAM (Internal), 512kbytes (battery backup)		
	Type	GT11-50BAT lithium battery		
	Backup target	Clock data, alarm history, recipe data, time action setting value, advanced alarm/advanced recipe, logging, hardcopy and SRAM user area		
	Life	Approx. 5 years (Operating ambient temperature of 25°C)		

Item	Specifications		
	GT1455-QTBD(E)	GT1450-QMBD(E)	GT1450-QLBD(E)
RS-422/485	RS-422/485 1ch Transmission speed : 115,200/57,600/38,400/19,200/9,600/4,800bps Connector shape : D-sub 9-pin (Female) Application : PLC communication Terminating resistor : Open/110Ω/330Ω (Switched by terminating resistor selector switch) <sup>6</sup> (At factory shipment: 330Ω)		
	RS-232 1ch Transmission speed : 115,200/57,600/38,400/19,200/9,600/4,800bps Connector shape : D-sub 9-pin (Male) Application : PLC communication, bar code reader, RFID connection, PC communication (Project data upload/download, OS installation, transparent function)		
Built-in interface	Ethernet (Only in models equipped with Ethernet interface) Data transfer method: 100BASE-TX/10BASE-T, 1ch Connector shape : RJ-45 (Modular jack) Application : PLC communication, Gateway functions, PC communication (Project data upload/download, OS installation, FA transparent function)		
	Host	USB (Full Speed 12Mbps), 1ch Connector shape : TYPE-A Application : Data transfer, data storage	
USB	Device	USB (Full Speed 12Mbps), 1ch Connector shape : Mini-B Application : PC communication (Project data upload/download, OS installation, FA transparent function)	
SD card	In conformance to SD standard, 1ch Applicable memory cards : SDHC memory card, SD memory card Application : Project data upload/download, OS installation, logging data storage		
Buzzer output	Single tone (tone length adjustable)		
Environmental protective structure <sup>7</sup>	Equivalent to IP67 (front section)		
External dimensions	W164(6.46) × H135(5.32) × D55(2.17)[mm](inch)(Excluding USB environmental protective cover) (Horizontal format)		
Panel cutting dimensions	W153 (6.03) × H121(4.77)[mm] (inch) (Horizontal format)		
Weight	Approx. 0.7kg (Excluding mounting fixtures)		
Compatible software package	GT Designer3 Version1.37P or later	GT Designer3 Version1.118Y or later	GT Designer3 Version1.37P or later

- \*1 • Bright dots (always lit) and dark dots (unlit) may appear on a liquid crystal display panel. It is impossible to completely avoid this symptom, as the liquid crystal display comprises of a great number of display elements. Flickers may be observed depending on the display color. Please note that these dots appear due to its characteristic and are not caused by product defect.
- Flickers and partial discoloration may be generated on the liquid crystal display panel due to the display contents or the contrast adjustment. However, please note that these phenomena appear due to its characteristic and are not caused by product defect.
- There is a difference in the display brightness and the color tones between liquid crystal display panels. When using multiple liquid crystal display panels, please note that there is an individual difference between them.
- A crosstalk (shadow as an extension of the display) may appear on the liquid crystal display panel. Please note that it appears due to its characteristic.
- When the display section is seen from the outside of the display angle, the display color seems like it has changed. Please note that it is due to its characteristic. Please note that the response time, brightness and color of the liquid crystal display panel may vary depending on the usage environmental temperature. Especially in the low temperature environment, the display response becomes slow due to the characteristics of the STN liquid crystal. Please check the display response in advance for using this product.
- When the same screen is displayed for a long time, an incidental color or partial discoloration is generated on the screen due to heat damage, and it may not disappear. To prevent heat damage, the screen saver function is effective. For details on the screen saver function, refer to the following.  
→ **GT14 User's Manual**
- Just after the GOT is powered off, sometimes an image lag or partial discoloration is generated temporary. However they are caused by the characteristic of the liquid crystal. (After powering off, they disappear within a few minutes.)

#### Appearance

White stripe patterns may appear on the surface of the resin molded part of the product. Please note that these phenomena appear due to the characteristics of the material used in the product and are not caused by product defect.

### 3.3 Power Supply Specifications

Item	Specifications	
	GT1455-QTBD, GT1450-QMBD, GT1450-QLBD	GT1455-QTBDE, GT1450-QMBDE, GT1450-QLBDE
Input power supply voltage	24VDC (+10% -15%), ripple voltage 200mV or less	
Fuse (built-in, not exchangeable)	1.6A	

Item	Specifications	
	GT1455-QTBD, GT1450-QMBD, GT1450-QLBD	GT1455-QTBDE, GT1450-QMBDE, GT1450-QLBDE
Power consumption	7.68W (320mA/24VDC) or less	8.40W (350mA/24VDC) or less
	At backlight off	6.72W (280mA/24VDC) or less
Inrush current	30A or less (26.4V) 2ms	
Permissible instantaneous power failure time <sup>1</sup>	Within 5ms	
Noise immunity	Noise voltage: 1000Vp-p, Noise width: 1μs (by noise simulator of 30 to 100Hz noise frequency)	
Dielectric withstand voltage	500VAC for 1 minute (across power supply terminals and earth)	
Insulation resistance	10MΩ or larger by insulation resistance tester (across power supply terminals and earth)	
Applicable wire size	For power supply: 0.75[mm <sup>2</sup> ] or more, For grounding: 2[mm <sup>2</sup> ] or more	
Applicable solderless terminal	Solderless terminal for M3 screw RAV1.25-3, V2-N3A, FV2-N3A	
Applicable tightening torque (Terminal block terminal screw)	0.5 to 0.8[N·m]	

\*1 The GOT continues to operate even upon 5ms or shorter instantaneous power failure.

The GOT stops operating if there is extended power failure or voltage drop, while it automatically resumes operation as soon as the power is restored.

### 3.4 External Dimensions

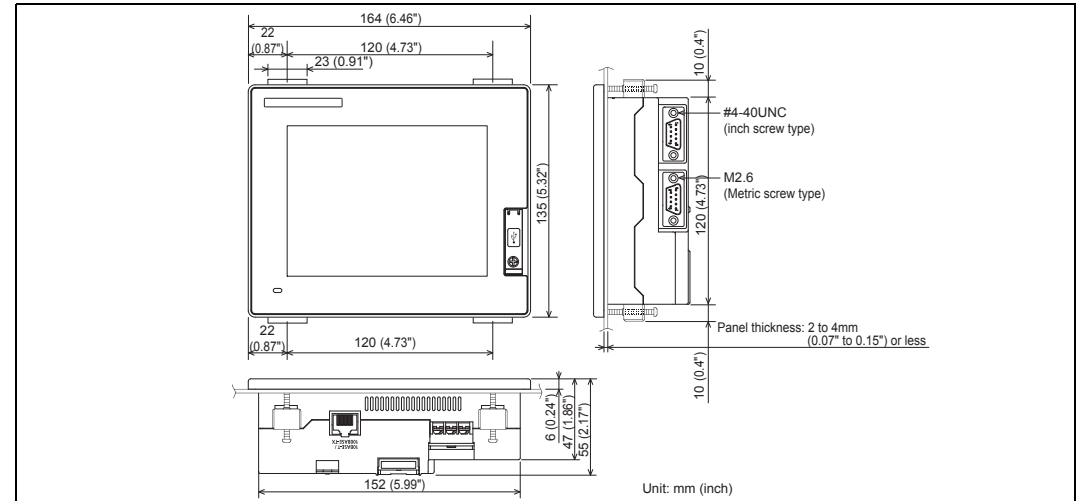

### 4. Installation

#### 4.1 Control Panel Inside Dimensions for Mounting GOT

Mount the GOT onto the control panel while considering the following control panel inside dimensions.

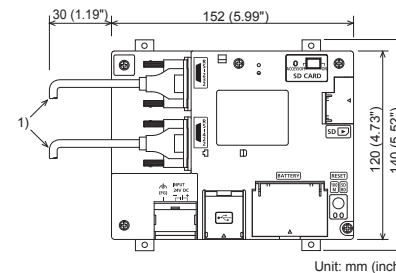

No	Name
1)	PLC connection cable/PC connection cable

#### Applicable cable

Some cables may need to be longer than the specified dimensions when connecting to the GOT. Therefore, consider the connector dimensions and bending radius of the cable as well for installation.

#### 4.2 Panel Cutting Dimensions

Make holes in the panel according to the dimensions list below. Also, ensure 10mm spaces in upper and lower parts of the panel for mounting fixtures.

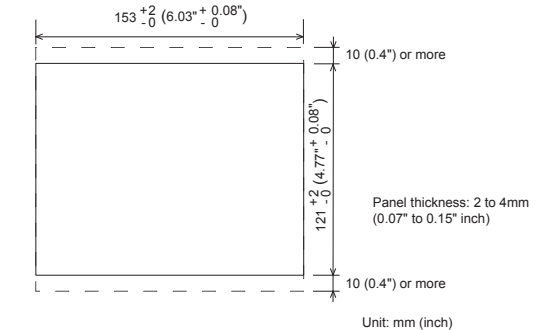

Unit: mm (inch)

### 4.3 Mounting Position

When mounting the GOT, the clearances shown on the right must be left from a structure or the other device.

Installation Environment	A,D	B	C	E
In the presence of radiated-noise or heat-generating equipment nearby	50 mm (1.97") or more	80 mm (3.14") or more*1	50 mm (1.97") or more*2	100 mm (3.93") or more
In the absence of radiated-noise or heat-generating equipment nearby	20 mm (0.79") or more	20 mm (0.79") or more	20 mm (0.79") or more	20 mm (0.79") or more

- \*1 Vertical format....50 mm (1.97") or more
- \*2 Vertical format....80 mm (3.14") or more

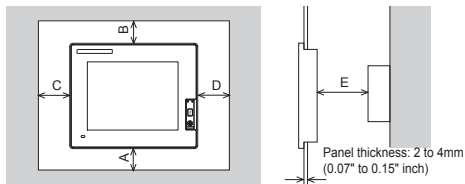

### 4.4 Control Panel Inside Temperature and Mounting Angle

When mounting the main unit to a control panel or similar, set the display section as shown below. When the temperature inside the control panel is 40 to 55°C (Horizontal mount), 40 to 50°C (Vertical mount), the mounting angle should be in the range 60° to 105° degrees.

- The GOT will be deteriorated earlier if it is used at the mounting angle other than the above. Therefore, the temperature inside the control panel should be within 40°C.

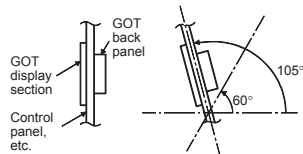

### 4.5 Installation Procedure

The GOT is designed to be embedded into a panel. Mount the GOT by following the procedure below. For panel cutting dimensions, refer to Section 4.2. Note that the panel thickness should be within 2 to 4mm.

- Installing the packing**  
Install packing to the packing installation groove on the back panel of the GOT. While referring to the cross sectional view of the packing shown right, push the thinner side into the packing groove. (Right drawing is the example of lateral format.)
- Inserting into the panel face**  
Insert the GOT from the front side of the panel.
- Fixing the GOT**  
Engage the hook of the mounting fitting (accessory) to the unit fixing hole of the GOT and tighten the screw until the GOT is fixed with the mounting bolt (accessory). The GOT will be fixed in 4 upper/lower parts. Tighten the mounting screw with the specified torque. (Failure to do so may distort the panel and make a surface waviness on the protective sheet.)
- A protection film is attached on the display section of GOT prior to shipment. Remove the film when the installation is completed.

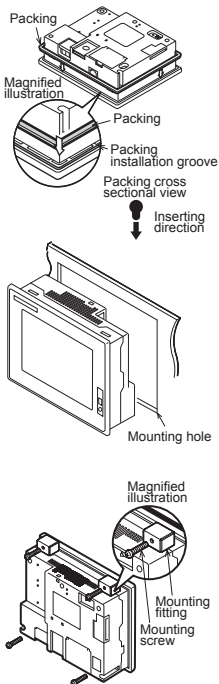

### 5. Wiring

#### 5.1 Power Supply Wiring

Connect the power supply to the power terminals on the back panel of the GOT. Use 0.75mm<sup>2</sup> or thicker cables to avoid voltage drop and tighten the terminal screw with the specified torque securely.

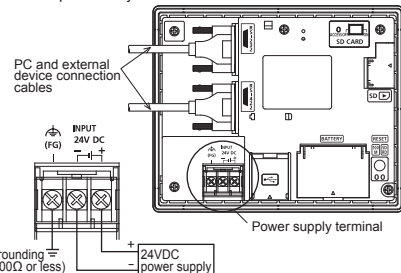

- Carry out the independent grounding if possible.
- If the independent grounding is impossible, carry out the shared grounding as shown in fig.2) below.
- Use the cable of 2mm<sup>2</sup> or more for grounding. Set the grounding point closer to the GOT to make the grounding cable short as possible.

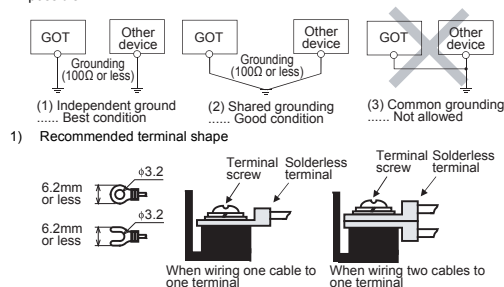

### 6. Maintenance and Inspection

The GOT does not include consumable components that will cause the shorten life. However, note that battery life is 5 years and LCD life is 50,000 hours. The life of backlight is 70,000 hours. It is recommended to replace the battery periodically. (For the replacement of the liquid crystal screen and backlight, please consult your nearest sales office or FA Center.) Refer to the following for the daily inspection and the periodic inspection. → **GT14 User's Manual**

#### 6.1 Battery Replacement

The battery is used for backing up the clock data, alarm history, recipe data, time action setting value, advanced alarm, advanced recipe, logging, hardcopy or SRAM user area. Screen data is stored in the flash memory and data is retained even if the battery is dead.

- Battery model name  
GT14□□ is shipped with the following battery.

Product name	Model name
Battery	GT11-50BAT

- Battery replacement procedure
  - Turn the GOT power off.
  - Open the battery cover of the GOT.
  - Remove the old battery from the GOT.
  - Disconnect the old battery connector and insert the new battery connector within 30s.
  - Insert the new battery into the GOT and close the battery cover.
  - Turn the GOT power on.
  - Check if the battery condition is normal with the utility. Refer to the following for the details of battery status display. → **GT14 User's Manual**

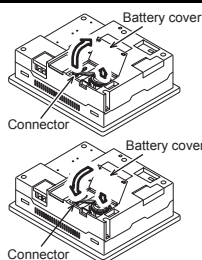

- How to confirm production year and month  
The production year and month of the battery built in the purchased GOT can be confirmed by the production No. (S/N) marked on the GOT main unit.

Example nameplate (manufacturer's serial number 1160003)

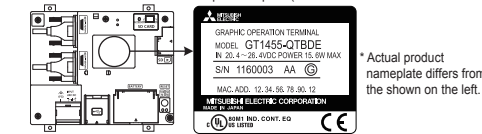

\*Actual product nameplate differs from the shown on the left.

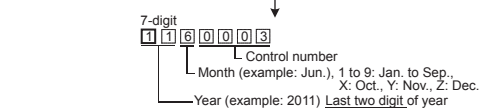

The production date of the optional replacement battery can be confirmed by the lot No. marked on the nameplate (label) affixed on the battery.

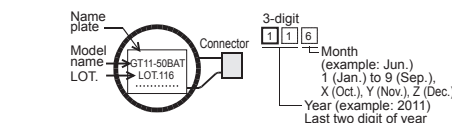

- Battery life  
Approximate battery life:  
5 years (ambient temperature: 25°C)  
Battery replacement: In 4 to 5 years

Approximate life is 5 years, but life may be shorter depending on the ambient temperature, therefore, note that the battery must be replaced in 4 to 5 years. Make sure to purchase a new battery as needed as it self-discharges.

Battery status can be confirmed on a GOT utility screen. For details of battery status or how to output alarm, refer to the following: → **GT14 User's Manual**

### 7. Notification of CE marking

The following products have shown compliance through direct testing (to the identified standards) and design analysis (forming a technical construction file) to the European Directive for Electromagnetic Compatibility (2004/108/EC) when used as directed by the appropriate documentation.

- This product is designed for use in industrial applications.
  - Type: Graphic Operation Terminal
  - Models: GOT series

Standard	Remark
EN6131-2 : 2007	Compliance with all relevant aspects of the standard. (Radiated Emissions)
Programmable controllers	Compliance with all relevant aspects of the standard. (ESD, RF electromagnetic field, EFTB, Surge, RF conducted disturbances and Power frequency magnetic field)
- Equipment, requirements and tests	

For more details please contact your local Mitsubishi Electric sales site. For details of CE marking, refer to the following. → **GT14 User's Manual**

#### 7.1 Notes regarding the use of GOT units

##### 7.1.1 General notes on the use of communication cables

Any device which utilizes a data communication function is susceptible to the wider effects of local EMC noise. Therefore, when installing any communication cables care should always be taken with the routing and location of those cables. Optional ferrite cores are recommended when the cable route is close to EMC noise sources like welders, large motors, etc. All tests have been performed with original Mitsubishi cables. For customer prepared cables, please refer to the manuals.

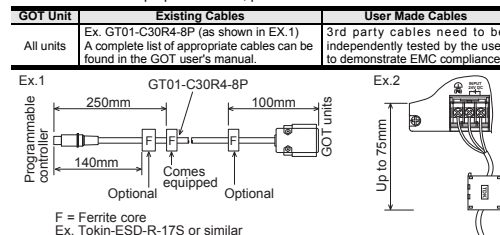

##### 7.1.2 General notes on power supply

All units require an additional ferrite filter to be attached to the 24V DC power supply cables. The filter should be attached in a similar manner as shown in the figure opposite, i.e. the power cables are wrapped around the filter. However, as with all EMC situations the more correctly applied precautions the better the system's electromagnetic compatibility. The ferrite recommended is a TDK ZCAT3035-1330 or similar (shown in Ex.2). The ferrite should be placed as near to the 24V DC terminals of the all units as possible (which should be within 75mm of the GOT terminal).

**Note: The customer must evaluate conformance of the final produced unit with the EMC directive.**

### 8. Certification of UL, cUL standards

- Environmental rating
  - Front: Type 4X (indoor use only)
  - Using GOT
  - GOT is for use on a flat surface of a Type 1 or Type 4X (indoor use only) enclosure

「电器电子产品有害物质限制使用标识要求」的表示方式



Note: This symbol mark is for China only.

含有有害6物质的名称, 含有量, 含有部品  
本产品中所含有的有害6物质的名称, 含有量, 含有部品如下表所示。

部件名称		有害物质					
		铅 (Pb)	汞 (Hg)	镉 (Cd)	六价铬 (Cr (VI))	多溴联苯 (PBB)	多溴二苯醚 (PBDE)
显示器 GOT	外壳	○	○	○	○	○	○
	印刷基板	×	○	○	○	○	○
	背光灯 (CCFL)	○	×	○	○	○	○
	电缆	×	○	○	○	○	○

本表格依据SJ/T 11364的规定编制。

- : 表示该有害物质在该部件所有均质材料中的含量均在GB/T 26572规定的限量要求以下。
- ×: 表示该有害物质至少在该部件的某一均质材料中的含量超出GB/T 26572规定的限量要求。

This manual confers no industrial property rights or any rights of any other kind, nor does it confer any patent licenses. Mitsubishi Electric Corporation cannot be held responsible for any problems involving industrial property rights which may occur as a result of using the contents noted in this manual.

#### Warranty

- Exclusion of loss in opportunity and secondary loss from warranty liability. Regardless of the gratis warranty term, Mitsubishi shall not be liable for compensation to:
- Damages caused by any cause found not to be the responsibility of Mitsubishi.
  - Loss in opportunity, lost profits incurred to the user by Failures of Mitsubishi products.
  - Special damages and secondary damages whether foreseeable or not, compensation for accidents, and compensation for damages to products other than Mitsubishi products.
  - Replacement by the user, maintenance of on-site equipment, start-up test run and other tasks.

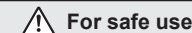

- This product has been manufactured as a general-purpose part for general industries, and has not been designed or manufactured to be incorporated in a device or system used in purposes related to human life.
- Before using the product for special purposes such as nuclear power, electric power, aerospace, medicine or passenger movement vehicles, consult with Mitsubishi Electric.
- This product has been manufactured under strict quality control. However when installing the product where major accidents or losses could occur if the product fails, install appropriate backup or failsafe functions in the system.

**MITSUBISHI ELECTRIC CORPORATION**

HEAD OFFICE : TOKYO BUILDING, 2-7-3 MARUNOUCHI, CHIYODA-KU, TOKYO 100-8310, JAPAN



GT1455-QTBD(E), GT1450-QMBD(E)  
GT1450-QLBD(E)

GT14 General Description

<b>GRAPHIC OPERATION TERMINAL</b> <b>GOT1000</b>	Manual Number	JY997D43901G
	Date	Oct. 2016

This manual describes the part names, dimensions, mounting, and specifications of the product. Before use, read this manual and manuals of relevant products fully to acquire proficiency in handling and operating the product. Make sure to learn all the product information, safety information, and precautions. And, store this manual in a safe place so that you can take it out and read it whenever necessary. Always forward it to the end user.

Registration  
Ethernet is a trademark of Xerox Corporation in the United States. The company name and the product name to be described in this manual are the registered trademarks or trademarks of each company.

Effective Oct. 2016  
Specifications are subject to change without notice.

© 2011 MITSUBISHI ELECTRIC CORPORATION

**Safety Precaution** (Read these precautions before using.)

Before using this product, carefully read this manual and the relevant manuals introduced in this manual and pay full attention to safety to handle the product correctly. The precautions given in this manual are concerned with this product. In this manual, the safety precautions are ranked as "WARNING" and "CAUTION".

<b>WARNING</b>	Indicates that incorrect handling may cause hazardous conditions, resulting in death or severe injury.
<b>CAUTION</b>	Indicates that incorrect handling may cause hazardous conditions, resulting in medium or slight personal injury or physical damage.

Depending on circumstances, procedures indicated by "CAUTION" may also be limited to serious results. In any case, it is important to follow the directions for usage.

**DESIGN PRECAUTIONS** **WARNING**

- Some failures of the GOT or cable may keep the outputs on or off. An external monitoring circuit should be provided to check for output signals which may lead to a serious accident.
- If a communication fault (including cable disconnection) occurs during monitoring on the GOT, communication between the GOT and PLC CPU is suspended and the GOT becomes inoperative. A system where the GOT is used should be configured to perform any significant operation to the system by using the switches of a device other than the GOT on the assumption that a GOT communication fault will occur. Not doing so can cause an accident due to false output or malfunction.
- Do not use the GOT as the warning device that may cause a serious accident. An independent and redundant hardware or mechanical interlock is required to configure the device that displays and outputs serious warning. Failure to observe this instruction may result in an accident due to incorrect output or malfunction.
- Incorrect operation of the touch switch(es) may lead to a serious accident if the GOT backlight is gone out. When the GOT backlight goes out, the POWER LED flickers (green/orange) and the display section turns black and causes the monitor screen to appear blank, while the input of the touch switch(es) remains active. This may confuse an operator in thinking that the GOT is in "screensaver" mode, who then tries to release the GOT from this mode by touching the display section, which may cause a touch switch to operate. Note that the following occurs on the GOT when the backlight goes out.
  - The POWER LED flickers (green/orange) and the monitor screen appears blank.
- The display section is an analog-resistive type touch panel. If you touch the display section simultaneously in 2 points or more, the switch that is located around the center of the touched point, if any, may operate. Do not touch the display section in 2 points or more simultaneously. Doing so may cause an accident due to incorrect output or malfunction.
- When programs or parameters of the controller (such as a PLC) that is monitored by the GOT are changed, be sure to reset the GOT or shut off the power of the GOT at the same time. Not doing so can cause an accident due to false output or malfunction.

**DESIGN PRECAUTIONS** **WARNING**

- When the security of the GOT and relevant information need to be protected against illegal access from an external device via the Internet, take measures at the user's discretion. Failure to do so may cause the configured information to be read out illegally.

**DESIGN PRECAUTIONS** **CAUTION**

- Do not bundle the control and communication cables with main-circuit, power or other wiring. Run the above cables separately from such wiring and keep them a minimum of 100mm (3.94in.) apart. Not doing so may cause a malfunction.
- Do not press the GOT display section with a pointed material as a pen or driver. Doing so can result in a damage or failure of the display section.
- When using the GOT with Ethernet connection, available IP addresses are restricted depending on the system configuration.
  - When connecting two or more GOT units to the Ethernet network: Do not specify the IP address "192.168.0.18" to the GOT or any connected equipment.
  - When connecting one GOT unit to the Ethernet network: Do not specify the IP address "192.168.0.18" to any connected equipment other than the GOT. If the IP address "192.168.0.18" is specified in the above system configuration, IP address overlap occurs when the GOT is started up, and adverse effect may be given to communication in the equipment in which the IP address "192.168.0.18" is set. Operation executed at IP address overlap varies depending on the equipment and system.
- Turn on the power of the connected equipment and network equipment, and make them ready for communication before connecting them to the GOT. If the connected equipment and network equipment are not ready for communication, a communication error may occur in the GOT.

**MOUNTING PRECAUTIONS** **WARNING**

- Be sure to shut off all phases of the external power supply used by the system before mounting or removing the GOT to/from the panel. Not doing so can cause the unit to fail or malfunction.

**MOUNTING PRECAUTIONS** **CAUTION**

- Use the GOT in the environment that satisfies the general specifications described in this manual. Not doing so can cause an electric shock, fire, malfunction or product damage or deterioration.
- When mounting the GOT to the control panel, tighten the mounting screws in the specified torque range. Undertightening can cause the GOT to drop, short circuit or malfunction, and deteriorate the waterproof effect and oilproof effect. Overtightening can cause a drop, short circuit or malfunction due to the damage of the screws or the GOT, and deteriorate the waterproof effect and oilproof effect due to distortion of the protective cover for oil, GOT or panel.
- Never drop cutting chips and electric wire chips into the ventilation window of the GOT when you drill screw holes or perform wiring. Otherwise, fire, failure or malfunction may be caused.
- When inserting/removing a SD card into/from the GOT, turn the SD card access switch off in advance. Failure to do so may corrupt data within the SD card.
- When removing a SD card from the GOT, make sure to support the SD card by hand, as it may pop out. Failure to do so may cause the SD card to drop from the GOT and break.
- When installing a USB memory to the GOT, make sure to install the USB memory to the USB interface firmly. Failure to do so may cause a malfunction due to poor contact.
- Before removing the USB memory from the GOT, operate the utility screen for removal. After the successful completion dialog box is displayed, remove the memory by hand carefully. Failure to do so may cause the USB memory to drop, resulting in a damage or failure of the memory.
- Operate and store the GOT in environments without direct sunlight, high temperature, dust, humidity, and vibrations.
- When using the GOT in the environment of oil or chemicals, use the protective cover for oil. Failure to do so may cause failure or malfunction due to the oil or chemical entering into the GOT.

**WIRING PRECAUTIONS** **WARNING**

- Be sure to shut off all phases of the external power supply used by the system before wiring. Failure to do so may result in an electric shock, product damage or malfunctions.
- Please make sure to ground FG terminal of the GOT power supply section by applying 100 or less which is used exclusively for the GOT. Not doing so may cause an electric shock or malfunction.

**WIRING PRECAUTIONS** **WARNING**

- Correctly wire the GOT power supply section after confirming the rated voltage and terminal arrangement of the product. Not doing so can cause a fire or failure.
- Tighten the terminal screws of the GOT power supply section in the specified torque range. Overtightening can cause a short circuit or malfunction. Overtightening can cause a short circuit or malfunction due to the damage of the screws or the GOT.
- Exercise care to avoid foreign matter such as chips and wire offcuts entering the GOT. Not doing so can cause a fire, failure or malfunction.

**WIRING PRECAUTIONS** **CAUTION**

- The cables connected to the unit must be run in ducts or clamped. Not doing so can cause the unit or cable to be damaged due to the dangling, motion or accidental pulling of the cables or can cause a malfunction due to a cable connection fault.
- When unplugging the cable connected to the unit, do not hold and pull the cable portion. Doing so can cause the unit or cable to be damaged or can cause a malfunction due to a cable connection fault.
- Plug the communication cable into the connector of the connected unit and tighten the mounting and terminal screws in the specified torque range. Undertightening can cause a short circuit or malfunction. Overtightening can cause a short circuit or malfunction due to the damage of the screws or unit.

**TEST OPERATION PRECAUTIONS** **WARNING**

- Before performing the test operations of the user creation monitor screen (such as turning ON or OFF bit device, changing the word device current value, changing the settings or current values of the timer or counter, and changing the buffer memory current value), read through the manual carefully and make yourself familiar with the operation method. During test operation, never change the data of the devices which are used to perform significant operation for the system. False output or malfunction can cause an accident.

**STARTUP/MAINTENANCE PRECAUTIONS** **WARNING**

- When power is on, do not touch the terminals. Doing so can cause an electric shock or malfunction.
- Connect the battery correctly. Do not discharge, disassemble, heat, short, solder or throw the battery into the fire. Incorrect handling may cause the battery to generate heat, burst or take fire, resulting in injuries or fires.
- Before starting cleaning or terminal screw retightening, always switch off the power externally in all phases. Not switching the power off in all phases can cause a unit failure or malfunction. Undertightening can cause a short circuit or malfunction. Overtightening can cause a short circuit or malfunction due to the damage of the screws or unit.

**STARTUP/MAINTENANCE PRECAUTIONS** **CAUTION**

- Do not disassemble or modify the unit. Doing so can cause a failure, malfunction, injury or fire.
- Do not touch the conductive and electronic parts of the unit directly. Doing so can cause a unit malfunction or failure.
- The cables connected to the unit must be run in ducts or clamped. Not doing so can cause the unit or cable to be damaged due to the dangling, motion or accidental pulling of the cables or can cause a malfunction due to a cable connection fault.
- When unplugging the cable connected to the unit, do not hold and pull the cable portion. Doing so can cause the unit or cable to be damaged or can cause a malfunction due to a cable connection fault.
- Do not drop or apply any impact to the battery. If any impact has been applied, discard the battery and never use it. The battery may be damaged by the drop or impact.
- Before touching the unit, always touch grounded metal, etc. to discharge static electricity from human body, etc. Not doing so can cause the unit to fail or malfunction.
- Replace battery with GT11-50BAT by Mitsubishi electric Co. only. Use of another battery may present a risk of fire or explosion.
- Dispose of used battery promptly. Keep away from children. Do not disassemble and do not dispose of in fire.

**DISPOSAL PRECAUTIONS** **CAUTION**

- When disposing of the product, handle it as industrial waste.
- When disposing of batteries, separate them from other wastes according to the local regulations. (For details of the battery directive in EU member states, refer GOT User's Manual.)

**TOUCH PANEL PRECAUTIONS** **CAUTION**

- For the analog-resistive film type touch panels, normally the adjustment is not required. However, the difference between a touched position and the object position may occur as the period of use elapses. When any difference between a touched position and the object position occurs, execute the touch panel calibration.
- When any difference between a touched position and the object position occurs, other object may be activated. This may cause an unexpected operation due to incorrect output or malfunction.

**TRANSPORTATION PRECAUTIONS** **CAUTION**

- When transporting lithium batteries, make sure to treat them based on the transport regulations. (Refer to User's Manual for details of the regulated models.)
- Before transporting the GOT, turn the GOT power on and check that the battery voltage status is normal on the Time setting & display screen (utilities screen). In addition, confirm that the adequate battery life remains on the rating plate. Transporting the GOT with the low battery voltage or the battery the reached battery life may destabilize the backup data unstable during transportation.
- Make sure to transport the GOT main unit and/or relevant unit(s) in the manner they will not be exposed to the impact exceeding the impact resistance described in the general specifications of this manual, as they are precision devices. Failure to do so may cause the unit to fail. Check if the unit operates correctly after transportation.

**Associated Manuals**  
The following manuals are relevant to this product. When these loose manuals are required, please consult with our local distributor.

Manual name	Contents	Manual Number (Model Code)
GT14 User's Manual (sold separately)	Describes the GT14 hardware-relevant content such as part names, external dimensions, mounting, power supply wiring, specifications, and introduction to option devices	JY997D44801 (09R823)
GT Designer3 Version1 Screen Design Manual (For GOT1000 Series) (Fundamentals) 1/2, 2/2 (sold separately) *1	Describes methods of the GT Designer3 installation operation, basic operation for drawing and transmitting data to GOT1000 series	SH-080866ENG (1D7M89)
GT Designer3 Version1 Screen Design Manual (For GOT1000 Series) (Functions) 1/2, 2/2 (sold separately) *1	Describes specifications and settings of the object functions used in GT Designer3	SH-080867ENG (1D7MC1)

\*1 Stored in the GT Works3/GT Designer3 in PDF format.  
For details of a PLC to be connected, refer to the PLC user's manual respectively.

**Bundled Items**

Product Name	Model Name	Specifications
GOT	GT1455-QTBD	5.7" diagonal [320 x 240 dots], TFT color (65536 colors), built-in battery and Ethernet interface
	GT1455-QTBD	5.7" diagonal [320 x 240 dots], TFT color (65536 colors), built-in battery
	GT1450-QMBDE	5.7" diagonal [320 x 240 dots], TFT monochrome (black/white), built-in battery and Ethernet interface
	GT1450-QMBD	5.7" diagonal [320 x 240 dots], TFT monochrome (black/white), built-in battery
	GT1450-QLBDE	5.7" diagonal [320 x 240 dots], STN monochrome (black/white), built-in battery and Ethernet interface
	GT1450-QLBD	5.7" diagonal [320 x 240 dots], STN monochrome (black/white), built-in battery

Bundled Item	Quantity
Mounting brackets	4
Mounting screws: M4 x 35mm (1.38")	4
Dust/Water-proof packing	1
GT14 General Description (This manual)	1

**1. Features**

- Improved monitoring performance and connectivity to FA devices
  - Multiple languages are displayed using the Unicode2.1-compatible fonts and beautiful characters are drawn using the TrueType and high quality fonts.
  - Two types of display modes are provided: 65536-colors display and monochrome display. In the monochrome display, 16 scales are used to improve the display. A fine and beautiful full-color display which shows even small characters clearly, is enabled by adopting the high intensity, wide viewing angle and high definition TFT color LCD. (Also compatible with digital screen displays with 65536 colors, BMP, etc.)
  - High-speed monitoring through high-speed serial communication at 115.2 kbps maximum or through Ethernet connection.
  - High speed display and high speed touch switch response.
- More efficient GOT operations including screen design, startup, adjustment, management and maintenance works
  - The 9MB built-in flash memory is included as standard.
  - SD card interface is included as standard.
  - RS-232 interface is included as standard.
  - RS-422/485 interface is included as standard.
  - USB interface (host/device) are included as standard.
  - Ethernet interface is included. (in some models)
- Enhanced support of FA setup tools
  - PLC program transfer and monitoring are possible via the personal computer that is connected to the GOT if connected directly to the A, QnA, L, Q, or FX series of the PLC CPU (FA transparent function).

**2. Part Name**

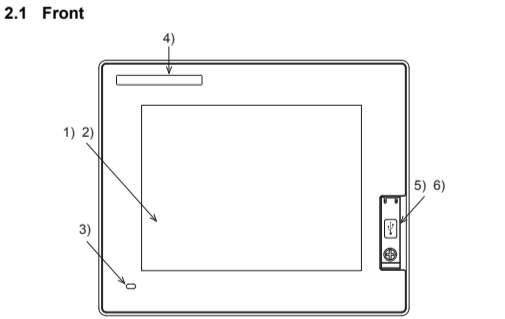

No.	Name	Specifications
1)	Display screen	Displays the utility screen and the user creation screen. GT1455-QTBD(E): 320x240 dots, TFT color liquid crystal GT1450-QMBD(E): 320x240 dots, TFT monochrome (white/black) liquid crystal, 16 scales GT1450-QLBD(E): 320x240 dots, STN monochrome (white/black) liquid crystal, 16 scales
2)	Touch panel	For operating the touch switches in the utility screen and the user creation screen
3)	POWER LED	Lit in green: Power is correctly supplied Lit in orange: Screen saving Blinking in orange/green: Blown backlight bulb Not lit: Power is not supplied
4)	Logo label	Removable
5)	USB interface	USB interface for connecting a personal computer (Device) OS installation, project data download, FA transparent
6)	USB environmental protection cover	Opens/Closes when the USB interface is used.

For the PC connection, refer to the following. → GT14 User's Manual

**2.2 Back/Bottom**

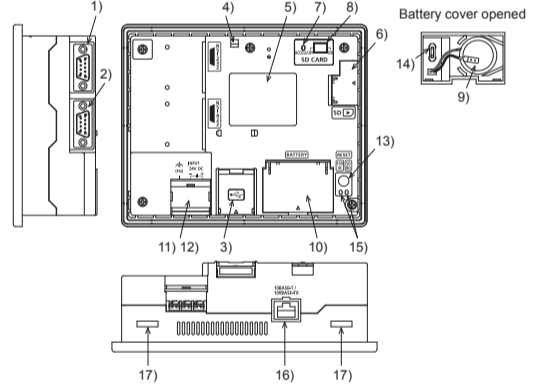

No.	Name	Specifications
1)	RS-232 interface	For communicating with controller or personal computer (D-sub 9-pin male)
2)	RS-422/485 interface	For communicating with controller (D-sub 9-pin female)
3)	USB interface	For data transfer, data storage USB interface (Host)
4)	Hole for preventing USB cable disconnection	Hole for fixing the USB cable with a cable tie (such as Insulock) to prevent disconnection
5)	Rating plate (nameplate)	--
6)	SD card interface	Interface for installing the SD card to GOT
7)	SD card access LED	Lit: SD card accessed Not lit: SD card not accessed
8)	SD card access switch	Switch for prohibiting access to SD card before removing the SD card from the GOT ON: SD card being accessed (SD card removal prohibited) OFF: No access to SD card (SD card removal possible)
9)	Battery	GT11-50BAT battery for storing clock data, alarm history and recipe data
10)	Battery cover	Open or close when replacing the battery. Opened and closed when the terminating resistor is changed over
11)	Power terminal	Power terminal and FG terminal (for power supply (24VDC) to GOT and grounding)
12)	Power terminal cover	Open or close when connecting a power terminal. (Color: transparent)
13)	Reset switch	Hardware reset switch (Use an isolated rod to operate.)
14)	Terminating resistor selector switch	Terminating resistor selector switch of RS-422/485 (330Ω/OPEN/110Ω)
15)	Ethernet communication status LED	SD RD: Turns on in green during data communication, 100M: Turns on in green during 100Mbps transmission.
16)	Ethernet interface	For connecting the equipment through Ethernet (RJ-45 connector)
17)	Hole for unit installation fitting	Hole for the inserting installation fittings (accessory) during the GOT installation to the panel (4 holes at top and bottom)

For the connection to the controller (PLC, microcomputer board, bar code reader, RFID, etc) or PC, refer to the following. → GT14 User's Manual

**3. Specifications**

**3.1 General Specifications**

Item	Specifications	
Operating ambient temperature	Display section: 0 to 50°C	
	Other than display section: 0 to 55°C (When mounted horizontally), 0 to 50°C (When mounted vertically)	
Storage ambient temperature	-20 to 60°C	
Operating ambient humidity	10 to 90% RH, non-condensing (STN liquid crystal type to be stored at or below 39°C WBT.)	
Storage ambient humidity	10 to 90% RH, non-condensing (STN liquid crystal type to be stored at or below 39°C WBT.)	
Vibration resistance	Conforms to JIS B3502 and IEC61131-2	
	Under intermittent vibration	Frequency: 5 to 8.4Hz, Acceleration: --, Half-amplitude: 3.5mm
	Under continuous vibration	8.4 to 150Hz: 9.8m/s <sup>2</sup> , 1.75mm
		5 to 8.4Hz: --, 4.9m/s <sup>2</sup> , --
Shock resistance	Conforms to JIS B3502, IEC 61131-2 (147 m/s <sup>2</sup> , 3 times each in X, Y and Z directions)	
Operating atmosphere	Must be free of lamp black, corrosive gas, flammable gas, or excessive amount of electro conductive dust particles and must be no direct sunlight. (Same as for saving)	
Operating altitude <sup>1)</sup>	2000 m (6562 ft) max.	
Installation location	Inside control panel	
Overvoltage category <sup>2)</sup>	II or less	
Pollution degree <sup>3)</sup>	2 or less	
Cooling method	Self-cooling	

- Do not use or store the GOT under pressure higher than the atmospheric pressure of altitude 0m (0ft.). Failure to observe this instruction may cause a malfunction. When the air inside the control panel is purged by pressurization, the surface sheet may be lifted by high pressure. As a result, the touch panel may be difficult to press, and the sheet may be peeled off.
- This indicates the section of the power supply to which the equipment is assumed to be connected between the public electrical power distribution network and the machinery within the premises. Category II applies to equipment for which electrical power is supplied from fixed facilities. The surge voltage withstand level for up to the rated voltage of 300 V is 2500 V.
- This index indicates the degree to which conductive material is generated in the environment where the equipment is used. In pollution degree 2, only non-conductive pollution occurs but temporary conductivity may be produced due to condensation.

**3.2 Performance Specifications**

Item	Specifications		
	GT1455-QTBD(E)	GT1450-QMBD(E)	GT1450-QLBD(E)
Display section <sup>1)</sup>	Type	TFT color liquid crystal	TFT monochrome (white/black) liquid crystal
	Screen size	5.7"	STN monochrome (white/black) liquid crystal
	Resolution	320 x 240 dots	
	Display size	W115(4.53) x H86(3.39)[mm](inch) (Horizontal format)	
	Display character	16-dot standard font: 20 characters x 15 lines, 12-dot standard font: 26 characters x 20 lines	
	Display color	65536 colors	Monochrome (white/black), 16 scales
	Display angle <sup>2)</sup>	Left/Right: 80 degrees, Top: 80 degrees, Bottom: 60 degrees (Horizontal format)	
	Contrast adjustment	--	32-level adjustment
	Intensity of LCD only	400[cd/m <sup>2</sup> ]	300[cd/m <sup>2</sup> ]
	Intensity adjustment	8-level adjustment	
Life	Approx. 50,000h. (Time for display intensity to become 1/5 at operating ambient temperature of 25°C)		
Backlight	Life	LED (irreplaceable by a user) Backlight off/screen saving time can be set. <sup>3)</sup>	
	Type	Analog resistive film touch panel	
Touch panel <sup>4)</sup>	Key size	Minimum 2 x 2 dots (per key)	
	Number of points touched simultaneously	Simultaneous presses not allowed. (Only 1 point can be touched.)	
	Life	1 million times or more (operating force 0.98N max.)	
Memory	C drive <sup>5)</sup>	Flash memory (internal), for storing project data (9Mbytes) and OS	
	Life (Number of write times)	100,000 times	
Battery	D drive	SRAM (internal), 512kbytes (battery backup)	
	Type	Magnesium manganese dioxide lithium primary battery	
Backup target	Life	Approx. 5 years (Operating ambient temperature of 25°C)	
	Life	Clock data, alarm history, recipe data, time action setting value, advanced alarm/advanced recipe, logging, hardcopy and SRAM user area	

Item	Specifications		
	GT1455-QTBD(E)	GT1450-QMBD(E)	GT1450-QLBD(E)
RS-422/485	RS-422/485 1ch Transmission speed : 115,200/57,600/38,400/19,200/9,600/4,800bps Connector shape : D-sub 9-pin (Female) Application : PLC communication Terminating resistor : Open/110Ω/330Ω (Switched by terminating resistor selector switch)*6 (At factory shipment: 330Ω)		
RS-232	RS-232 1ch Transmission speed : 115,200/57,600/38,400/19,200/9,600/4,800bps Connector shape : D-sub 9-pin (Male) Application : PLC communication, bar code reader, RFID connection, PC communication (Project data upload/download, OS installation, transparent function)		
Built-in interface	Ethernet (Only in models equipped with Ethernet interface)	Data transfer method: 100BASE-TX/10BASE-T, 1ch Connector shape : RJ-45 (Modular jack) Application : PLC communication, Gateway functions, PC communication (Project data upload/download, OS installation, FA transparent function)	
	USB	USB (Full Speed 12Mbps), 1ch Connector shape : TYPE-A Application : Data transfer, data storage	
SD card	Host	USB (Full Speed 12Mbps), 1ch Connector shape : Mini-B Application : PC communication (Project data upload/download, OS installation, FA transparent function)	
	Device	In conformance to SD standard, 1ch Applicable memory cards : SDHC memory card, SD memory card Application : Project data upload/download, OS installation, logging data storage	
Buzzer output	Single tone (tone length adjustable)		
Environmental protective structure*7	Equivalent to IP67 (front section)		
External dimensions	W164(6.46) × H135(5.32) × D55(2.17)[mm](inch)(Excluding USB environmental protective cover) (Horizontal format)		
Panel cutting dimensions	W153 (6.03) × H121(4.77)[mm] (inch) (Horizontal format)		
Weight	Approx. 0.7kg (Excluding mounting fixtures)		
Compatible software package	GT Designer3 Version1.37P or later	GT Designer3 Version1.118Y or later	GT Designer3 Version1.37P or later

- \*1 Bright dots (always lit) and dark dots (unlit) may appear on a liquid crystal display panel. It is impossible to completely avoid this symptom, as the liquid crystal display comprises of a great number of display elements. Flickers may be observed depending on the display color. Please note that these dots appear due to its characteristic and are not caused by product defect.
- \*2 Gradation inversion is a characteristic of liquid crystal displays. Please be forewarned that depending on the displayed color, the visualization may be difficult even within the described view angle.
- \*3 Using the GOT Backlight OFF function can prolong the life of the backlight. For details on the Backlight OFF function, refer to the following.  
→ **GT14 User's Manual**
- \*4 The touch panel is analog resistive film-type. If you touch the panel simultaneously in 2 points or more, the switch that is located around the center of the touched point, if any, may operate. Do not touch the panel in 2 points or more simultaneously. Do not press the GOT display section with a pointed material as a pen or driver. Doing so can result in a damage or failure of the display section. For the analog-resistive film type touch panels, normally the adjustment is not required. However, the difference between a touched position and the object position may occur as the period of use elapses. When any difference between a touched position and the object position occurs, execute the touch panel calibration. When any difference between a touched position and the object position occurs, other object may be activated. This may cause an unexpected operation due to incorrect output or malfunction.
- \*5 ROM in which new data can be written without deleting the written data.
- \*6 Set the terminating resistor selector switch of the GOT in accordance with the connection type when adopting GOT multidrop connection. For details of GOT multidrop connection, refer to the following.  
→ **GOT1000 Series Connection Manual**
- \*7 Compliant with IP67 when the USB environmental protection cover is attached. Not compliant when a USB cable is connected. Note that this does not guarantee all users' operation environment. The protection is not applied when the interface environment protection cover is removed. In addition, the product may not be used in environments under exposition of oil or chemicals for a long period of time, or in environments filled with oil-mist.
- Please note that the response time, brightness and color of the liquid crystal display panel may vary depending on the usage environmental temperature. Especially in the low temperature environment, the display response becomes slow due to the characteristics of the STN liquid crystal. Please check the display response in advance for using this product.
- When the same screen is displayed for a long time, an incidental color or partial discoloration is generated on the screen due to heat damage, and it may not disappear. To prevent heat damage, the screen saver function is effective. For details on the screen saver function, refer to the following.  
→ **GT14 User's Manual**
- Just after the GOT is powered off, sometimes an image lag or partial discoloration is generated temporarily. However they are caused by the characteristic of the liquid crystal. (After powering off, they disappear within a few minutes.)

**Appearance**  
White stripe patterns may appear on the surface of the resin molded part of the product. Please note that these phenomena appear due to the characteristics of the material used in the product and are not caused by product defect.

### 3.3 Power Supply Specifications

Item	Specifications		
	GT1455-QTBD, GT1450-QMBD, GT1450-QLBD	GT1455-QTBE, GT1450-QMBDE, GT1450-QLBDE	
Input power supply voltage	24VDC (+10% -15%), ripple voltage 200mV or less		
Fuse (built-in, not exchangeable)	1.6A		

### 4.3 Mounting Position

When mounting the GOT, the clearances shown on the right must be left from a structure or the other device.

Installation Environment	A, D	B	C	E
In the presence of radiated-noise or heat-generating equipment nearby	50 mm (1.97") or more	80 mm (3.14") or more*1	50 mm (1.97") or more*2	100 mm (3.93") or more
In the absence of radiated-noise or heat-generating equipment nearby	20 mm (0.79") or more	20 mm (0.79") or more	20 mm (0.79") or more	20 mm (0.79") or more

- \*1 Vertical format...50 mm (1.97") or more  
\*2 Vertical format...80 mm (3.14") or more

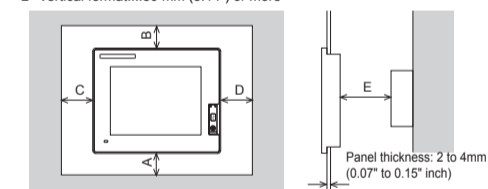

### 4.4 Control Panel Inside Temperature and Mounting Angle

When mounting the main unit to a control panel or similar, set the display section as shown below.  
When the temperature inside the control panel is 40 to 55°C (Horizontal mount), 40 to 50°C (Vertical mount), the mounting angle should be in the range 60° to 105° degrees.

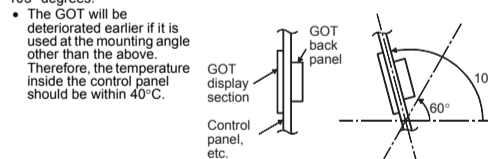

### 4.5 Installation Procedure

The GOT is designed to be embedded into a panel. Mount the GOT by following the procedure below. For panel cutting dimensions, refer to Section 4.2. Note that the panel thickness should be within 2 to 4mm.

- Installing the packing  
Insert packing to the packing installation groove on the back panel of the GOT. While referring to the cross sectional view of the packing shown right, push the thinner side into the packing groove. (Right drawing is the example of lateral format.)
- Inserting into the panel face  
Insert the GOT from the front side of the panel.
- Fixing the GOT  
Engage the hook of the mounting fitting (accessory) to the unit fixing hole of the GOT and tighten the screw until the GOT is fixed with the mounting bolt (accessory). The GOT will be fixed in 4 upper/lower parts.  
Tighten the mounting screw with the specified torque. (Failure to do so may distort the panel and make a surface waviness on the protective sheet.)
- A protection film is attached on the display section of GOT prior to shipment. Remove the film when the installation is completed.

### 5. Wiring

#### 5.1 Power Supply Wiring

Connect the power supply to the power terminals on the back panel of the GOT. Use 0.75mm<sup>2</sup> or thicker cables to avoid voltage drop and tighten the terminal screw with the specified torque securely.

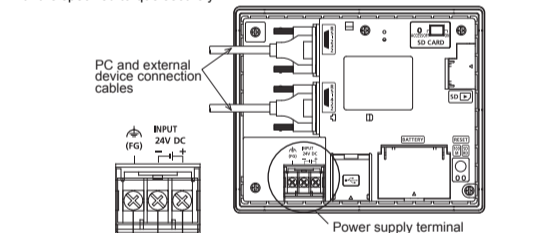

- Carry out the independent grounding if possible.
- If the independent grounding is impossible, carry out the shared grounding as shown in fig.2) below.
- Use the cable of 2mm<sup>2</sup> or more for grounding.
- Set the grounding point closer to the GOT to make the grounding cable short as possible.

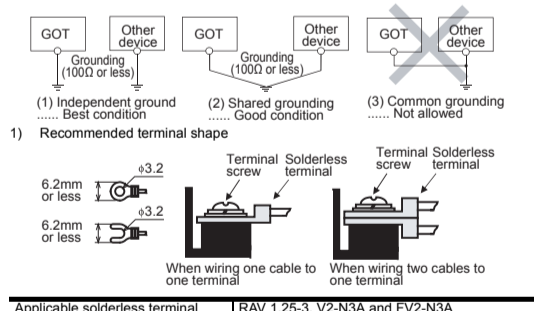

Applicable solderless terminal : RAV1.25-3, V2-N3A and V2-N3A

### 6. Maintenance and Inspection

The GOT does not include consumable components that will cause the shorten life. However, note that battery life is 5 years and LCD life is 50,000 hours. The life of backlight is 70,000 hours. It is recommended to replace the battery periodically. (For the replacement of the liquid crystal screen and backlight, please consult your nearest sales office or FA Center.) Refer to the following for the daily inspection and the periodic inspection.  
→ **GT14 User's Manual**

#### 6.1 Battery Replacement

The battery is used for backing up the clock data, alarm history, recipe data, time action setting value, advanced alarm, advanced recipe, logging, hardcopy or SRAM user area. Screen data is stored in the flash memory and data is retained even if the battery is dead.

- Battery model name  
GT14□□ is shipped with the following battery.  

Product name	Model name
Battery	GT11-50BAT
- Battery replacement procedure  
1) Turn the GOT power off.  
2) Open the battery cover of the GOT.  
3) Remove the old battery from the GOT.  
4) Disconnect the old battery connector and insert the new battery connector within 30s.  
5) Insert the new battery into the GOT and close the battery cover.  
6) Turn the GOT power on.  
7) Check if the battery condition is normal with the utility.  
Refer to the following for the details of battery status display.  
→ **GT14 User's Manual**

Item	Specifications		
	GT1455-QTBD, GT1450-QMBD, GT1450-QLBD	GT1455-QTBE, GT1450-QMBDE, GT1450-QLBDE	
Power consumption	7.68W (320mA/24VDC) or less	8.40W (350mA/24VDC) or less	
At backlight off	6.72W (280mA/24VDC) or less	7.44W (310mA/24VDC) or less	
Inrush current	30A or less (26.4V) 2ms		
Permissible instantaneous power failure time*1	Within 5ms		
Noise immunity	Noise voltage: 1000Vp-p, Noise width: 1μs (by noise simulator of 30 to 100Hz noise frequency)		
Dielectric withstand voltage	500VAC for 1 minute (across power supply terminals and earth)		
Insulation resistance	10MΩ or larger by insulation resistance tester (across power supply terminals and earth)		
Applicable wire size	For power supply: 0.75[mm <sup>2</sup> ] or more, For grounding: 2[mm <sup>2</sup> ] or more		
Applicable solderless terminal	Solderless terminal for M3 screw RAV1.25-3, V2-N3A, V2-N3A		
Applicable tightening torque (Terminal block terminal screw)	0.5 to 0.8[N·m]		

- \*1 The GOT continues to operate even upon 5ms or shorter instantaneous power failure. The GOT stops operating if there is extended power failure or voltage drop, while it automatically resumes operation as soon as the power is restored.

### 3.4 External Dimensions

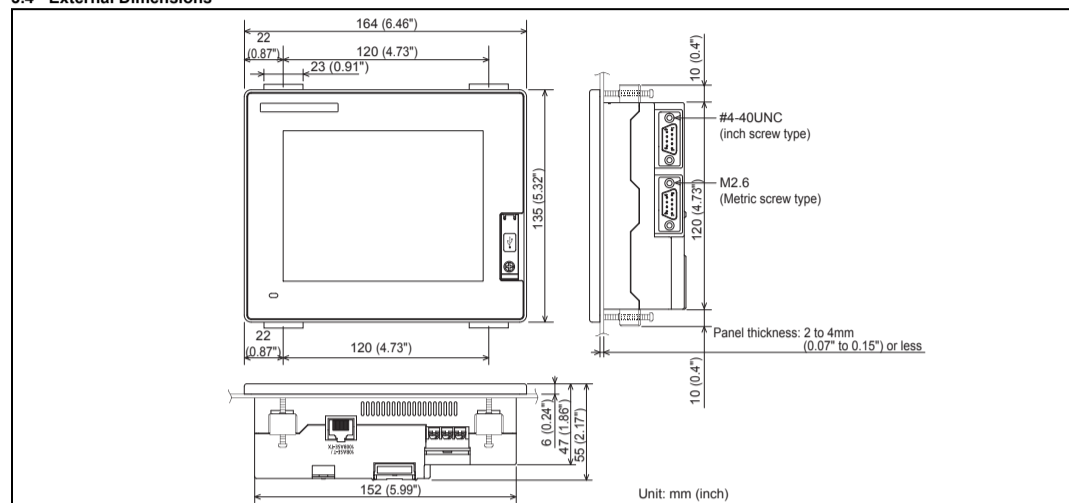

### 4. Installation

#### 4.1 Control Panel Inside Dimensions for Mounting GOT

Mount the GOT onto the control panel while considering the following control panel inside dimensions.

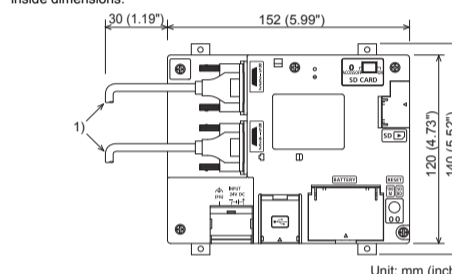

#### 4.2 Panel Cutting Dimensions

Make holes in the panel according to the dimensions list below. Also, ensure 10mm spaces in upper and lower parts of the panel for mounting fixtures.

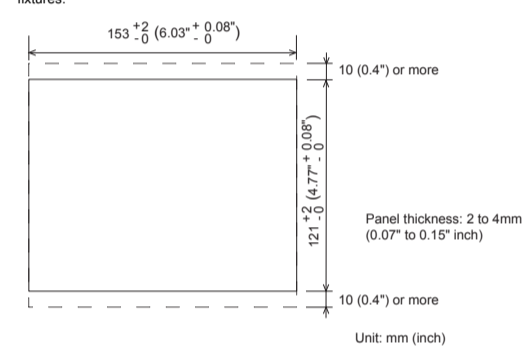

No	Name
1)	PLC connection cable/PC connection cable

**Applicable cable**  
Some cables may need to be longer than the specified dimensions when connecting to the GOT. Therefore, consider the connector dimensions and bending radius of the cable as well for installation.

- How to confirm production year and month  
The production year and month of the battery built in the purchased GOT can be confirmed by the production No. (S/N) marked on the GOT main unit.

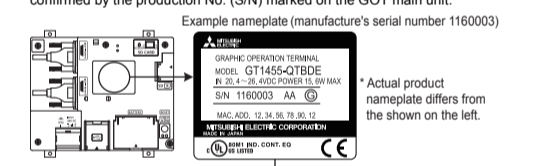

The production date of the optional replacement battery can be confirmed by the lot No. marked on the nameplate (label) affixed on the battery.

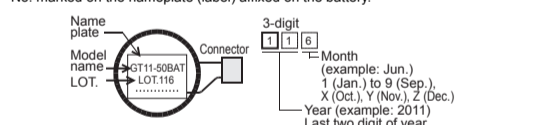

- Battery life  
Approximate battery life:  
5 years (ambient temperature: 25°C)  
Battery replacement: in 4 to 5 years  
Approximate life is 5 years, but life may be shorter depending on the ambient temperature, therefore, note that the battery must be replaced in 4 to 5 years. Make sure to purchase a new battery as needed as its self-discharges.

Battery status can be confirmed on a GOT utility screen. For details of battery status or how to output alarm, refer to the following.  
→ **GT14 User's Manual**

### 7. Notification of CE marking

The following products have shown compliance through direct testing (to the identified standards) and design analysis (forming a technical construction file) to the European Directive for Electromagnetic Compatibility (2004/108/EC) when used as directed by the appropriate documentation.

- This product is designed for use in industrial applications.  
- Type: Graphic Operation Terminal  
- Models: GOT series

Standard	Remark
EN61131-2 : 2007	EMI Compliance with all relevant aspects of the standard. (Radiated Emissions)
Programmable controllers - Equipment, requirements and tests	EMS Compliance with all relevant aspects of the standard. (ESD, RF electromagnetic field, EFTB, Surge, RF conducted disturbances and Power frequency magnetic field)

For more details please contact your local Mitsubishi Electric sales site. For details of CE marking, refer to the following.  
→ **GT14 User's Manual**

#### 7.1 Notes regarding the use of GOT units

##### 7.1.1 General notes on the use of communication cables

Any device which utilizes a data communication function is susceptible to the wider effects of local EMC noise. Therefore, when installing any communication cables care should always be taken with the routing and location of those cables. Optional ferrite cores are recommended when the cable route is close to EMC noise sources like welders, large motors, etc. All tests have been performed with original Mitsubishi cables. For customer prepared cables, please refer to the manuals.

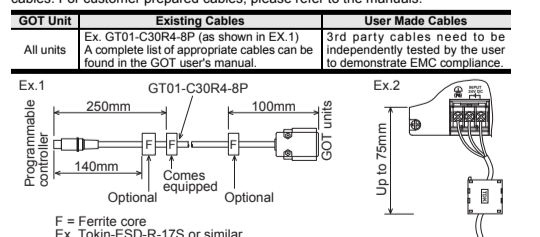

##### 7.1.2 General notes on power supply

All units require an additional ferrite filter to be attached to the 24V DC power supply cables. The filter should be attached in a similar manner as shown in the figure opposite, i.e. the power cables are wrapped around the filter. However, as with all EMC situations the more correctly applied precautions the better the system's electromagnetic compatibility. The ferrite recommended is a TDK ZCAT3035-1330 or similar (shown in Ex.2). The ferrite should be placed as near to the 24V DC terminals of the all units as possible (which should be within 75mm of the GOT terminal).

**Note: The customer must evaluate conformance of the final produced unit with the EMC directive.**

### 8. Certification of UL, cUL standards

- Environmental rating  
Front: Type 4X (indoor use only)
- Using GOT  
GOT is for use on a flat surface of a Type 1 or Type 4X (indoor use only) enclosure

「电器电子产品有害物质限制使用标识要求」的表示方式



Note: This symbol mark is for China only.

含有有害6物质的名称, 含有量, 含有部品  
本产品中所含有的有害6物质的名称, 含有量, 含有部品如下表所示。

部件名称	产品中有害物质的名称及含量					
	铅 (Pb)	汞 (Hg)	镉 (Cd)	六价铬 (Cr(VI))	多溴联苯 (PBB)	多溴二苯醚 (PBDE)
外壳	○	○	○	○	○	○
印刷基板	×	○	○	○	○	○
背光灯 (CCFL)	○	×	○	○	○	○
电缆	×	○	○	○	○	○

本表格依据SJ/T 11364的规定编制。

- : 表示该有害物质在该部件所有均质材料中的含量均在GB/T 26572规定的限量要求以下。
- ×: 表示该有害物质至少在该部件的某一均质材料中的含量超出GB/T 26572规定的限量要求。

This manual confers no industrial property rights or any rights of any other kind, nor does it confer any patent licenses. Mitsubishi Electric Corporation cannot be held responsible for any problems involving industrial property rights which may occur as a result of using the contents noted in this manual.

**Warranty**  
Exclusion of loss in opportunity and secondary loss from warranty liability  
Regardless of the gratis warranty term, Mitsubishi shall not be liable for compensation to:  
(1) Damages caused by any cause found not to be the responsibility of Mitsubishi.  
(2) Loss in opportunity, lost profits incurred to the user by Failures of Mitsubishi products.  
(3) Special damages and secondary damages whether foreseeable or not, compensation for accidents, and compensation for damages to products other than Mitsubishi products.  
(4) Replacement by the user, maintenance of on-site equipment, start-up test run and other tasks.

**For safe use**

- This product has been manufactured as a general-purpose part for general industries, and has not been designed or manufactured to be incorporated in a device or system used in purposes related to human life.
- Before using the product for special purposes such as nuclear power, electric power, aerospace, medicine or passenger movement vehicles, consult with Mitsubishi Electric.
- This product has been manufactured under strict quality control. However when installing the product where major accidents or losses could occur if the product fails, install appropriate backup or failsafe functions in the system.