

XALD363B

dark grey station - green flush/red flush pushbuttons
Ø22 and red pilot light



Main

Range of product	Harmony XALD
Product or component type	Complete control station
Device short name	XALD
Product destination	For XB5 Ø 22 mm control and signalling units
Control station application	Start-Stop function
Colour of base of enclosure	Light grey RAL 7035
Colour of cover	Dark grey RAL 7016
Material	Polycarbonate
Operator profile	2 flush push-buttons - 1 central pilot light
Operators description	Green "I" 1 NO - red "O" 1 NC
Control station composition	1 pilot light 1 flush push-button green 1 NO I marking 1 flush push-button red 1 NC O marking
Marking location	Marking on push-button
Contacts operation	Slow-break
Light source	Integrated and protected LED
Light source colour	Red
[Us] rated supply voltage	24 V AC/DC

Complementary

Cable entry	2 knock-outs for cable entry, clamping capacity: <= 14 mm 2 knock-outs for Pg 13 cable gland and ISO M20, clamping capacity: <= 12 mm
Product weight	0.261 kg
Resistance to high pressure washer	7000000 Pa at 55 °C, distance: 0.1 m
Colour of marking	Black marking when white caps White marking when green, red or black caps
Positive opening	With conforming to EN/IEC 60947-5-1 appendix K
Operating travel	1.5 mm (NC changing electrical state) 2.6 mm (NO changing electrical state) 4.3 mm (total travel)
Operating force	3.5 N (NC changing electrical state) 3.8 N (NO changing electrical state)
Mechanical durability	10000000 cycles
Connections - terminals	Screw clamp terminals : <= 2 x 1.5 mm ² with cable end conforming to EN/IEC 60947-1 Screw clamp terminals : >= 1 x 0.22 mm ² without cable end conforming to EN/IEC 60947-1
Tightening torque	0.8...1.2 N.m conforming to EN/IEC 60947-1
Shape of screw head	Cross, Philips no 1 Cross, pozidriv No 1 Slotted, flat Ø 4 mm Slotted, flat Ø 5.5 mm
Contacts material	Silver alloy (Ag/Ni)
Short circuit protection	10 A by gG cartridge fuse conforming to EN/IEC 60947-5-1
[Ith] conventional free air thermal current	10 A conforming to EN/IEC 60947-5-1
[Ui] rated insulation voltage	600 V (degree of pollution: 3) conforming to EN/IEC 60947-1
[Uimp] rated impulse withstand voltage	6 kV conforming to EN/IEC 60947-1
[Ie] rated operational current	AC-15, A600: Ue = 120 V Ie = 6 A conforming to EN/IEC 60947-5-1 AC-15, A600: Ue = 240 V Ie = 3 A conforming to EN/IEC 60947-5-1 AC-15, A600: Ue = 600 V Ie = 1.2 A conforming to EN/IEC 60947-5-1 DC-13, Q600: Ue = 125 V Ie = 0.55 A conforming to EN/IEC 60947-5-1 DC-13, Q600: Ue = 250 V Ie = 0.27 A conforming to EN/IEC 60947-5-1

DC-13, Q600: Ue = 600 V Ie = 0.1 A conforming to EN/IEC 60947-5-1

Electrical durability	1000000 cycles AC-15, 2 A at 230 V, operating rate: 3600 cyc/h, load factor: 0.5 conforming to EN/IEC 60947-5-1 appendix C 1000000 cycles AC-15, 3 A at 120 V, operating rate: 3600 cyc/h, load factor: 0.5 conforming to EN/IEC 60947-5-1 appendix C 1000000 cycles AC-15, 4 A at 24 V, operating rate: 3600 cyc/h, load factor: 0.5 conforming to EN/IEC 60947-5-1 appendix C 1000000 cycles DC-13, 0.2 A at 110 V, operating rate: 3600 cyc/h, load factor: 0.5 conforming to EN/IEC 60947-5-1 appendix C 1000000 cycles DC-13, 0.5 A at 24 V, operating rate: 3600 cyc/h, load factor: 0.5 conforming to EN/IEC 60947-5-1 appendix C
Electrical reliability IEC 60947-5-4	$\Lambda < 10\text{exp}(-6)$ at 5 V, 1 mA conforming to EN/IEC 60947-5-4 $\Lambda < 10\text{exp}(-8)$ at 17 V, 5 mA conforming to EN/IEC 60947-5-4
Signalling type	Steady
Supply voltage limits	19.2...30 V DC 21.6...26.4 V AC
Current consumption	18 mA
Service life	100000 h at rated voltage and 25 °C
Surge withstand	1 kV conforming to IEC 61000-4-5

Environment

protective treatment	TH
ambient air temperature for storage	-40...70 °C
ambient air temperature for operation	-40...70 °C
overvoltage category	Class II conforming to IEC 60536
IP degree of protection	IP67 IP66 conforming to IEC 60529 IP69K IP69
NEMA degree of protection	NEMA 13 NEMA 4X
IK degree of protection	IK05 conforming to EN 50102
standards	EN/IEC 60947-1 EN/IEC 60947-5-1 EN/IEC 60947-5-4 EN/IEC 60947-5-5 JIS C 4520 UL 508 CSA C22.2 No 14
product certifications	CSA UL listed
vibration resistance	5 gn (12...500 Hz) conforming to IEC 60068-2-6
shock resistance	30 gn (duration = 18 ms) for half sine wave acceleration conforming to IEC 60068-2-27 50 gn (duration = 11 ms) for half sine wave acceleration conforming to IEC 60068-2-27
resistance to fast transients	2 kV conforming to IEC 61000-4-4
resistance to electromagnetic fields	10 V/m conforming to IEC 61000-4-3
resistance to electrostatic discharge	6 kV on contact (on metal parts) conforming to IEC 61000-4-2 8 kV in free air (in insulating parts) conforming to IEC 61000-4-2
electromagnetic emission	Class B conforming to IEC 55011

Contractual warranty

Warranty period	18 months
-----------------	-----------

Dimensions

mm
in.

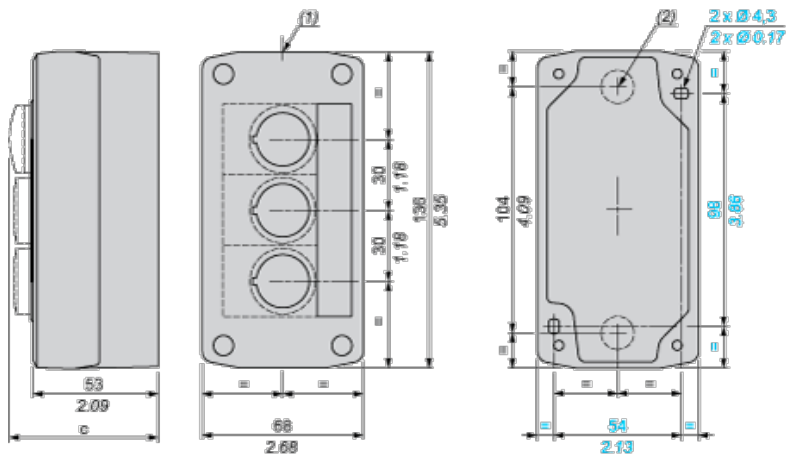

- (1) 2 knock-outs for Pg 13.5 cable gland, maximum capacity 12 mm/0.47 in.
 (2) Knock-out for cable entry, maximum capacity 14 mm/0.55 in.

Control station fitted with:	c in mm	c in in.
Flush pushbutton	62	2.44
Illuminated pushbutton	64	2.52
Pilot light	65.5	2.58
Projecting pushbutton	66	2.60
Selector switch	80	3.15
Key switch	105.5	4.15