

Datasheet
RS Stock No. 1242600
RS Pro Float Switch



The MC Series cable-end float switch is insensitive to humidity and condensation and is designed to control liquids up to 130°C and a maximum pressure of 4 bar. Because of the temperature at which this float switch is used, the outer casing is made from 304 AISI stainless steel and the 5m electric cable is equipped with an outer sheath resistant to high temperature. Two cable types are available - polyurethane and silicone, to suit the fluid being measured.

The switching element is a microswitch, with gold plated contacts, activated by a moving stainless steel ball and having an electrical life of 200,000 operations. Non-hygroscopic closed cell expanded polyurethane is injected around the switch housing within the outer casing, hermetically sealing the unit. The microswitch is suitable for low power applications such as PLC use and other electronic uses.

When used with the polyurethane cable it is suitable for use in fuel oils. Note, the cable is non-replaceable, in case of damage the whole device must be replaced.

Each unit is supplied complete with a counterweight

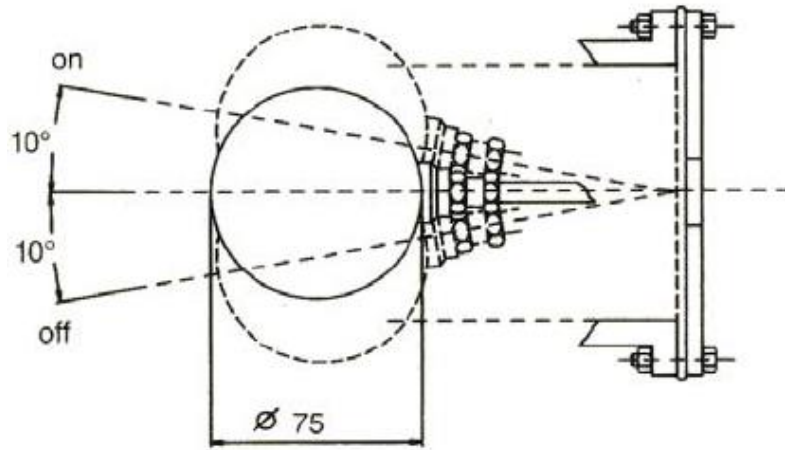
Technical Specifications				
RS Stock No.	1242598	1242599	1242600	1242601
Part No.	MC05A	MC05AH	MC05B	MC05BH
Contact Form	N/O		N/C	
Switching Current Max. Resistive (A)	0.25			
Power Rating (VA)	3			
Max DC V	60			
Cable Material	Polyurethane	Silicone	Polyurethane	Silicone
Cable length	5m with protective earth wire included			
Body Material	304 Stainless steel			
Temp Range °C	0 / +80	0 / +130	0 / +80	0 / +130
°F	+ 32 / +176	+ 32 / +266	+ 32 / +176	+ 32 / +266
Max. working pressure bar	4			



Side Mount
(thru side wall)

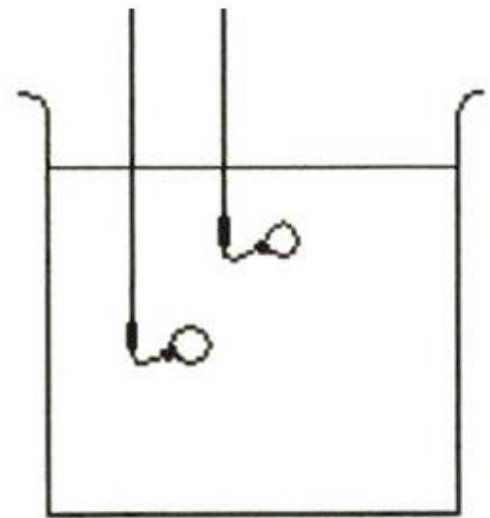

Top Mount
(using counterweight)