



CUSTOMISED

AUTO-BLOQUEO SELF-LOCKING COUPLE D'AUTOBLOQUEAGE SELBSTHEMMUNG	✓
RUEDA DE BRONCE BRONZE WHEEL ROUE EN BRONZE GETRIEBERAD AUS BRONZE	✓
EJE DELANTERO Y POSTERIOR FRONT AND REAR SHAFT ARBRE ARRIERE VORDERWELLE UND HINTERWELLE	✓
SENSOR HALL HALL SENSOR CAPTEUR HALL HALLSENSOR	✓

**Y MUCHO MÁS
AND MANY MORE
ET BEAUCOUP D'AUTRES
UND VIELEN ANDEREN**

REFERENCIA REFERENCE NUMBER REFERENZNUMMERN	TENSIÓN NOMINAL NOMINAL VOLTAGE TENSION NOMINALE NENNSPANNUNG	PAR NOMINAL NOMINAL TORQUE COUPLE NOMINAL DREHMOMENT NOMINAL	VELOCIDAD NOMINAL NOMINAL SPEED VITESSE NOMINALE GESCHWINDIGKEIT NOMINAL	CORRIENTE NOMINAL NOMINAL CURRENT COURANT NOMINAL NOMINALSTROM	PAR DE ARRANQUE STARTING TORQUE COUPLE DE DEVIARRAGE ANZUGSDREHMOMENT	CORRIENTE DE ARRANQUE STARTING CURRENT COURANT DE DEVIARRAGE ANLAUFSTROM	EJE SHAFT ARBRE WELLE	CONEXIONES CONNECTIONS CONNEXIONS ANSCHLUSSART	ESQUEMA ELÉCTRICO WIRING DIAGRAM SCHEMA ELECTRIQUE SCHALTBIID	RELACIÓN DE REDUCCIÓN TRANSMISSION RATIO RAPPORT DE REDUCTEUR ÜBERSETZUNG	PESO APROXIMADO APPROXIMATE WEIGHT POIDS APPROXIMATIF GEWICHT (Gg.)	GRADO DE ESTANQUEIDAD WATER TIGHTNESS ÉTANCHÉTE FLUCHTIGKEITSSCHUTZKLASSE	MATERIAL RUEDA WHEEL MATERIAL MATERIAU ROUE MAT. DES SCHNECKENRADES	CURVA CURVE COURBE KURVE
	Un (V)	Mn (N.m./lbf.in)	nn (r.p.m.)	In (A)	Ma (N.m./lbf.in)	Ia (A)				i	P (kg/lb.t)	IP		
316.2711.20.00	12	2 / 17.70	38	3.4	10 / 88.5	12	E22	C30	EE4	62:1	0.90/2.41	IP40	PLA	56
316.2711.30.00	24	2 / 17.70	38	1.7	10 / 88.5	6	E22	C30	EE4	62:1	0.90/2.41	IP40	PLA	56
316.2761.20.00	12	2 / 17.70	38	3.4	10 / 88.5	12	E30	C30	EE4	62:1	0.90/2.41	IP40	PLA	56
316.2761.30.00	24	2 / 17.70	38	1.7	10 / 88.5	6	E30	C30	EE4	62:1	0.90/2.41	IP40	PLA	56
316.2761.20.00E	12	2 / 17.70	38	3.4	10 / 88.5	12	E30	C30	F4	62:1	0.90/2.41	IP40	PLA	56
316.2761.30.00E	24	2 / 17.70	38	1.7	10 / 88.5	6	E30	C30	F4	62:1	0.90/2.41	IP40	PLA	56
316.9728.30.00	24	2 / 17.70	38	1.7	10 / 88.5	6	E30	C30	EE4	62:1	0.90/2.41	IP40	BRO	56
316.9731.20.00	12	*1.5/13.27	65	6.0	10 / 88.5	22	E30	C30	EE4	62:1	0.90/2.41	IP40	PLA	57
316.9731.30.00	24	*1.5/13.27	65	3.0	10 / 88.5	11	E30	C30	EE4	62:1	0.90/2.41	IP40	PLA	57

* (VDE 0530) S3 - 10% (10 min.)

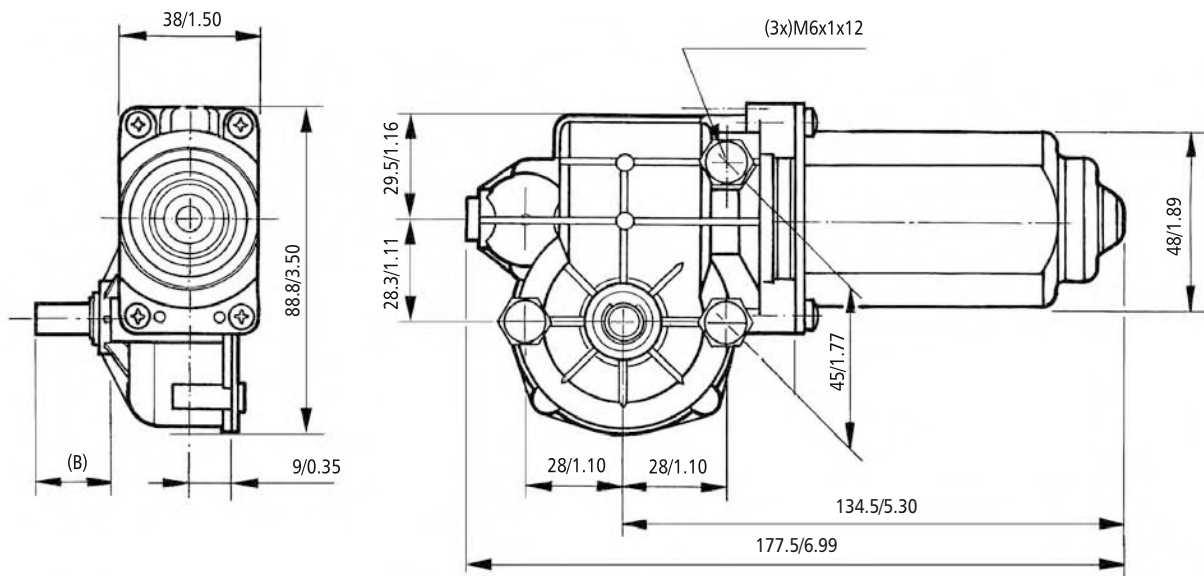

mm / in

EJE - SHAFT - ARBRE - WELLE

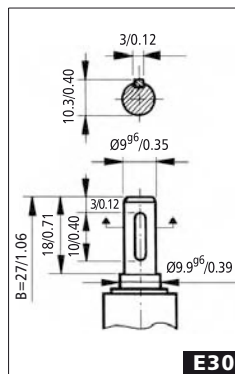
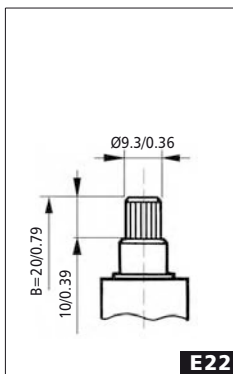

CONEXIONES - CONNECTIONS - CONNEXIONS - ANSCHLUSSART

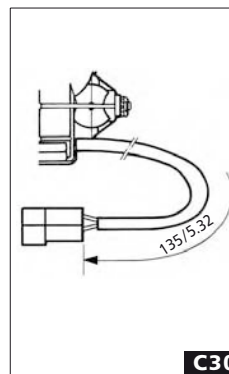

ESQUEMA ELÉCTRICO - WIRING DIAGRAM
SCHEMA ÉLECTRIQUE - SCHALTBILD

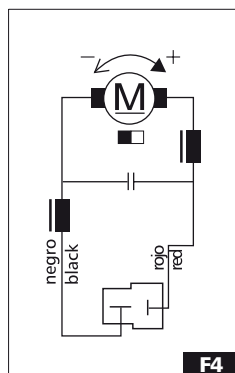
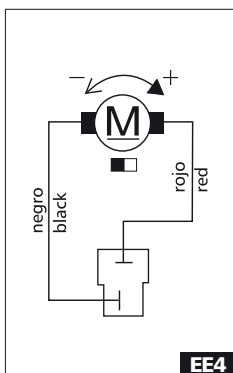

CURVAS - CURVES - COURBES - KURVEN

