

XCS M
pre-cabled

With head for linear movement (plunger). Mounting by the body

520576

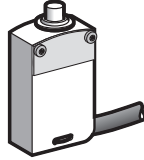

page 3/76

With head for rotary movement (lever). Mounting by the body

520577

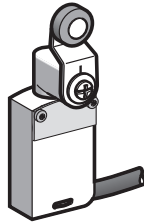

page 3/76

Environment		
Conforming to standards	Products	IEC/EN 60947-5-1, UL 508, CSA C22-2 No. 14
	Machine assemblies	IEC/EN 60204-1, EN 1088
Product certifications		UL, CSA
Protective treatment		Standard version: "TC"
Ambient air temperature		Operation: - 13...+ 158 °F(- 25...+ 70 °C). Storage: - 40...+ 158 °F (- 40...+ 70 °C)
Vibration resistance		XCS M snap action: 5 gn. XCS M slow break: 25 gn (10...500 Hz) conforming to IEC 60068-2-6
Shock resistance		25 gn, (18 ms) conforming to IEC 60068-2-27
Electric shock protection		Class I, conforming to IEC 6140 and NF C 20-030
Degree of protection		IP 66, IP 67 and IP 68 (1) conforming to IEC 60529; IK 06 conforming to EN 50102
Materials		Body: zamak. Head: zamak. Protective cover: steel.
Repeat accuracy		0.002 in. (0.05 mm) on the tripping points with 1 million operating cycles for head with end plunger

Contact block characteristics	
Rated operational characteristics	~ AC-15; B300 (Ue = 240 V, Ie = 1.5 A) --- DC-13 ; R300 (Ue = 250 V, Ie = 0.1 A), conforming to IEC 60947-5-1 Appendix A, EN 60947-5-1
Rated insulation voltage	Ui = 400 V degree of pollution 3 conforming to IEC 60947-5-1 Ui = 300 V conforming to UL 508, CSA C22-2 No. 14
Rated impulse withstand voltage	U imp = 4 kV conforming to IEC 60947-1, IEC 60664
Positive operation (depending on model)	N.C. contacts with positive opening operation conforming to IEC/EN 60947-5-1 Appendix K
Resistance across terminals	≤ 25 mΩ conforming to IEC 60255-7 category 3
Short-circuit protection	6 A cartridge fuse type gG (gl)
Minimum actuation speed	Snap action contact: 0.01 m/minute Break before make, slow break: 6 m/minute

Electrical life	<ul style="list-style-type: none"> ■ Conforming to 60947-5-1 Appendix C ■ Utilisation category AC-15 and DC-13 ■ Maximum frequency: 3600 operating cycles/hour ■ Load factor: 0.5
-----------------	---

a.c. supply
~ 50/60 Hz
mm inductive circuit

XCS M snap action
(N.C.+ N.C. + N.O., N.C.+ N.C. + N.O. + N.O. contacts)

XCS M slow break
(N.C.+ N.C. + N.O. contact)

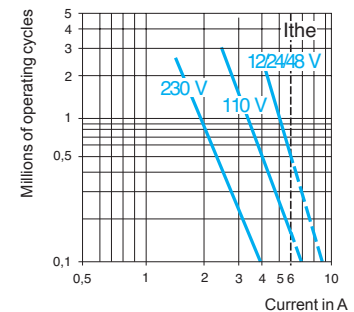
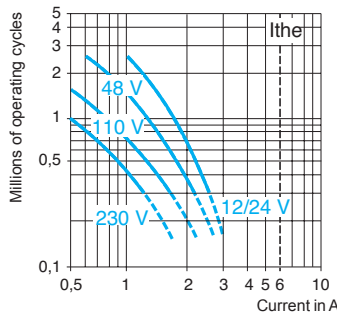

d.c. supply ---

Power broken in W for 5 million operating cycles				
Voltage	V	24	48	120
mm	W	3	2	1

Power broken in W for 5 million operating cycles				
Voltage	V	24	48	120
mm	W	4	3	3

Electrical Life

The product life expressed is based on average usage and normal operating conditions. Actual operating life will vary with conditions. The above statements are not intended to nor shall they create any express or implied warranties as to product operation or life. For information on the limited warranty offered on this product please refer to the Square D® terms and conditions of sale found in the Square D® Digest.

Type of head	Plunger (mounting by the body)	Rotary (mounting by the body)	
--------------	--------------------------------	-------------------------------	--

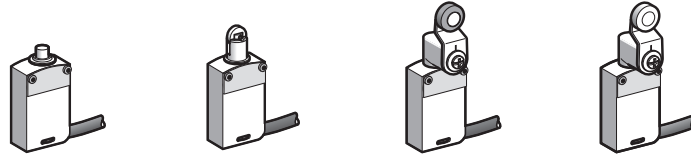

Type of operator	Metal end plunger	Roller plunger	Thermoplastic roller lever	Steel roller lever
------------------	-------------------	----------------	----------------------------	--------------------

References with 6.6 ft (2 m) cable (1)

	3-pole N.C.+N.C.+N.O. snap action contact	XCS M3910L2 	XCS M3902L2 	XCS M3915L2 	XCS M3916L2
	3-pole N.C.+N.C.+N.O. break before make, slow break contact	XCS M3710L2 	XCS M3702L2 	XCS M3715L2 	XCS M3716L2
	4-pole N.C.+N.C.+N.O.+N.O. snap action contact	XCS M4110L2 	XCS M4102L2 	XCS M4115L2 	XCS M4116L2
Weight oz (kg)	5.820 (0.165)	5.997 (0.170)	7.231 (0.205)	7.408 (0.210)	
Contact operation			(A) = cam displacement (P) = positive opening point ⊖ N.C. contact with opening positive operation		

Complementary characteristics not shown under general characteristics (page 3/75)

Switch actuation	On end	By 30° cam	
Type of actuation			
Maximum actuation speed	1.64 ft/s (0.5 m/s)	1.64 ft/s (0.5 m/s)	4.9 ft/s (1.5 m/s)
Minimum force or torque	Tripping: 1.9 lb (8.5 N) Positive opening: 9.6 lb (42.4 N)	Tripping: 1.6 lb (7 N) Positive opening: 7.9 lb (35 N)	Tripping: 0.9 lb-in (0.1 N•m) Positive opening: 4.4 lb-in (0.5 N•m)
Cabling	3-pole contacts: PVR pre-cabled, 7 x 20 AWG (0.5 mm ²) 4-pole contacts: PVR pre-cabled, 9 x 22 AWG (0.34 mm ²)		

(1) Devices shown have a 6.6 ft (2 m) cable, and are available with other lengths of cable:
 For a 3.3 ft (1 m) long cable, replace L2 with L1.
 For a 16.4 ft (5 m) long cable, replace L2 with L5.

Dimensions

XCSM ●●10L1

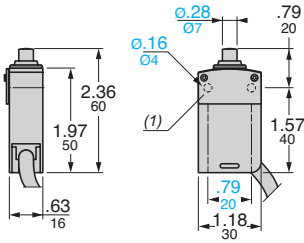

(1) Protective cover mounted with 5-lobe torque safety screws.

XCSM ●●02L1

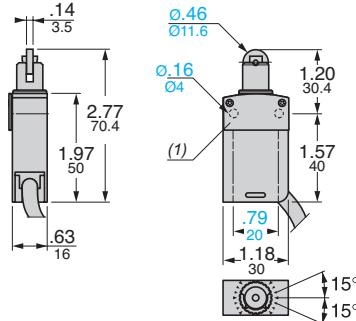

XCSM ●●15L1

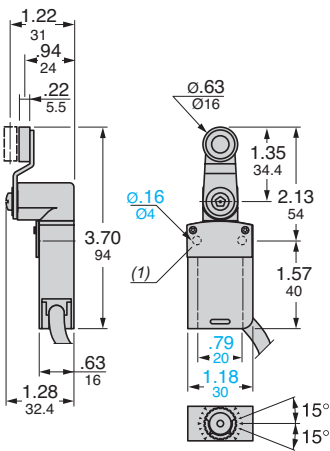

(1) Protective cover mounted with 5-lobe torque safety screws.

XCSM ●●16L1

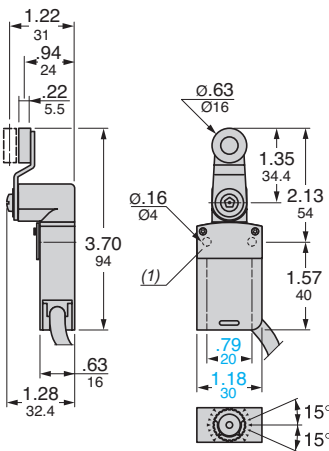

Dual Dimensions: INCHES
Millimeters

Wiring diagrams

Wiring to category 1 conforming to EN 954-1/
IEC 13849-1

Example with 3-pole N.C.+N.C.+N.O. contact and protective fuse to prevent jumpering of the N.C. contacts, either by cable damage or by tampering.

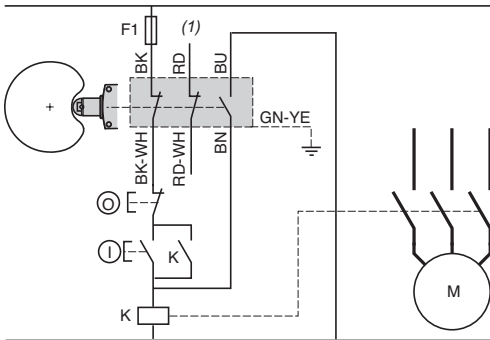

(1) Signalling contact

Wiring to category 3 conforming to EN 954-1/IEC 13849-1

Example with 3-pole N.C.+N.C.+N.O. contact with mixed redundancy of the contacts and the associated control relays. Opening and closing of the guard necessary to activate K1.

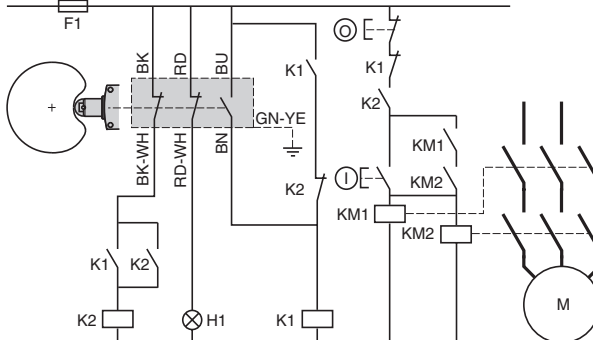

H1: "guard closed" indicator light

Example of guard monitoring using 2 switches and 1 safety relay module (category 4)

Operation in positive and negative (combined) mode

