

1	Input M12 - 4 pin female connector to connect pressure transmitter
2	4-position rotary switch to configure the product
3	Potentiometer to select the display value range and adjust the threshold value. Also used to select NO/NC and Locking function
4	4 digits, 7 segments display
5	Pressure unit indication
6	Yellow LED to indicate output 1 status: LED On = "Out 1" On
7	Yellow LED to indicate output 2 status: LED On = "Out 2" On
8	Output M12 - 4 pin male connector

**Note:** You can download this user guide, plus other languages from our website at: [www.tesensors.com](http://www.tesensors.com)  
We welcome your comments about this document. You can reach us by e-mail at: [customer-support@tesensors.com](mailto:customer-support@tesensors.com)

**CAUTION**

**UNINTENDED EQUIPMENT OPERATION**

- Read the user guide before the first installation.
- Use the equipment within the characteristics mentioned in catalogue.
- Use insulated SELV(\*) or PELV(\*\*) power supply.

**Failure to follow these instructions can result in injury or equipment damage.**

(\*) SELV: Safety extra low voltage

(\*\*) PELV: Protected extra low voltage

**Main characteristics:**

**Output configuration:**

Reference	ZMLPA1P2SH	ZMLPA1N2SH	ZMLPA1P2SW	ZMLPA1N2SW	ZMLPA2P0SH	ZMLPA2N0SH
Front face caption						
Analogue output	4...20 mA	4...20 mA	4...20 mA	4...20 mA	No / Non	No / Non
Switching output	PNP	NPN	PNP	NPN	2 x PNP	2 x NPN
Switching mode	Hysteresis	Hysteresis	Window	Window	Hysteresis	Hysteresis
Connector wiring						

Power supply	--- 24 Vdc SELV or PELV(*) power supply, operating range from 17 to 33 Vdc
Current consumption	≤ 50mA
Switching outputs	Switching capacity ≤ 200 mA with short-circuit & overload protection
	Voltage drop ≤ 2V
Analogue output	4...20 mA: load: ≤ 500 Ω (24V) ≤ 200 Ω (17V)
Operating temperature range	-25 to +70 °C (-13 to +158 °F)
Degree of protection	IP65, IP67 conforming to EN/IEC 60529 IP69K conforming to DIN 40050
Overall accuracy (analogue, digital output, display)	< 1% of the selected display range
Response time	≤ 5 ms

(\*) SELV: Safety extra low voltage / PELV: Protected extra low voltage

**Dimensions and tightening torques :**

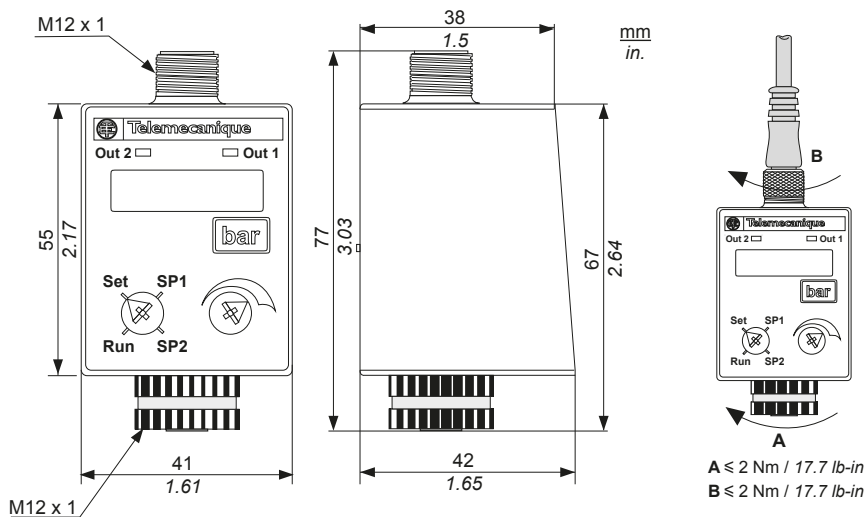

Electrical equipment should be installed, operated and maintained only by qualified personnel. No responsibility is assumed by Schneider Electric for any consequences arising out of the use of this material.

© 2014 Schneider Electric. "All Rights Reserved."

**Wiring Diagram:**

Input M12 4-pin female connector

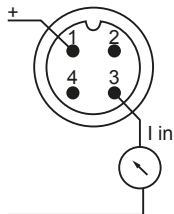

**CAUTION**

**UNINTENDED EQUIPMENT OPERATION**

- Only connect a 4-20mA pressure transmitter, directly or thanks to M12-M12 4-pin electrical jumper.
  - Make sure the pressure transmitter pin out and analogue signal is compatible with ZMLP if it is not a Telemecanique one.
- Failure to follow these instructions can result in injury or equipment damage.

**Mounting possibility:**

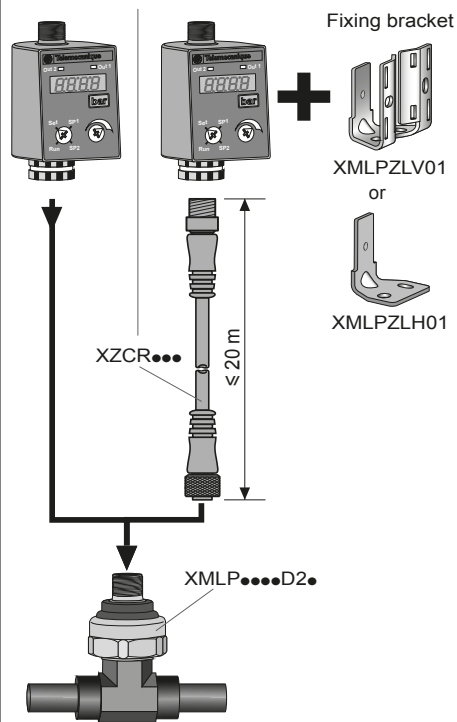

**Usage precautions:**

$T_{max} = 80^{\circ}\text{C} (176^{\circ}\text{F})$

$1/8'' \le \varnothing \le 1/4''$

**Setting Head position**

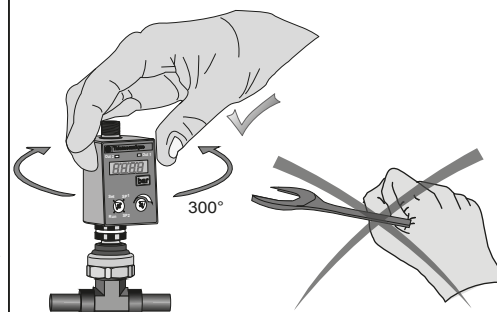
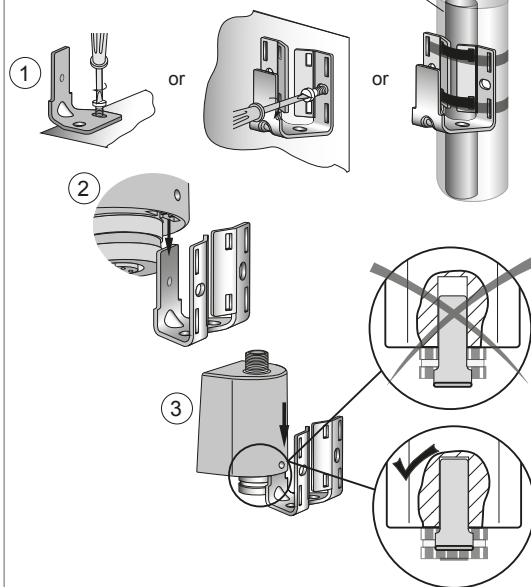

**Output description:**

**Switching output:**

**Hysteresis mode:**

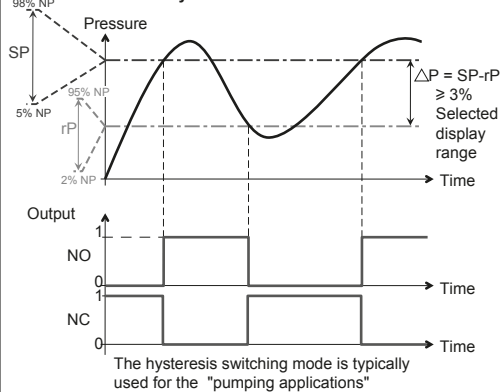

**Analogue output:**

- The 4-20mA analogue output is strictly the image of the pressure transmitter output signal

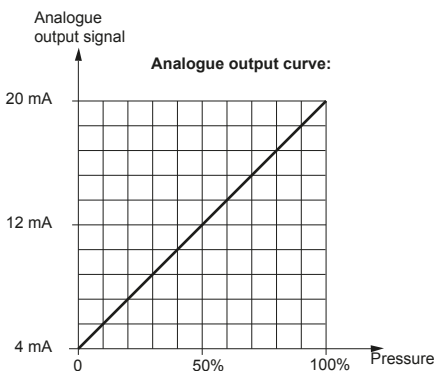

**Maintenance:**

At each power on, all the display segments are simultaneously lit up briefly. This allows the operator to check that all segments are well operating.

**Cleaning**

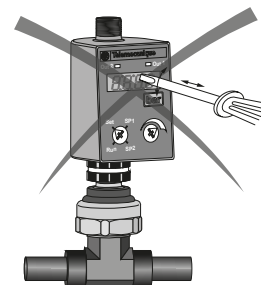
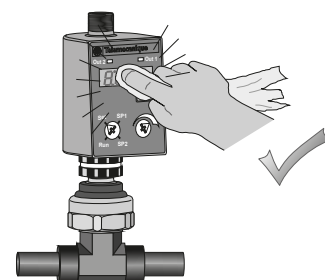

**Window mode:**

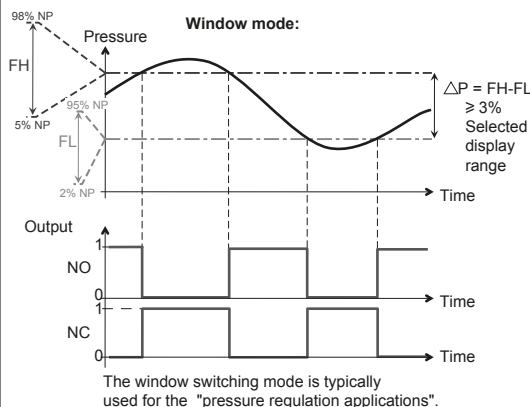

**Two switching outputs:**

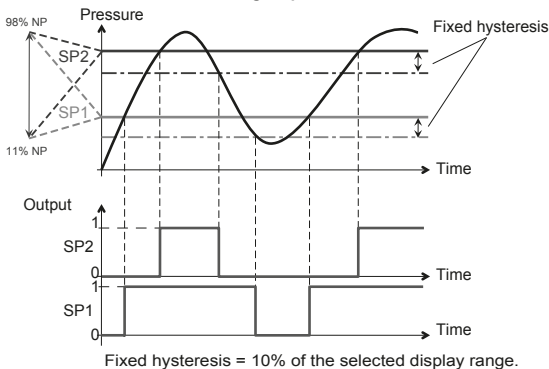

**Setting:**

**1 Choose the pressure unit in accordance to the connected pressure transmitter:** The default unit is «bar».

psi, kPa and MPa adhesive labels provided with the product can be stuck on the front face in the place of «bar».

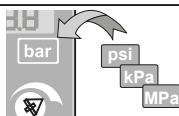

**2 Select the displayed value range in accordance to the connected pressure transmitter.**

Put the rotary switch on «Set» position (factory default position). «Set» and a value are alternatively displayed.

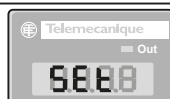
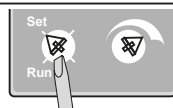

Then select the appropriate value by turning the potentiometer.

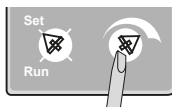

The change of rotary switch position memorizes the selected value.

**3 Adjust the high pressure threshold (Set Point):**

Put the rotary switch on «SP» or «FH» or «SP1» position (depending on model). «SP» or «FH» or «SP1» and threshold value are alternatively displayed.

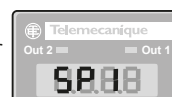
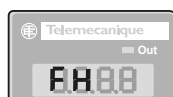
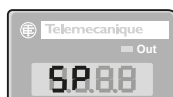
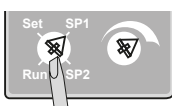
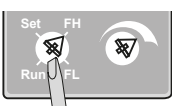
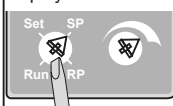

Then adjust the threshold value by turning the potentiometer.

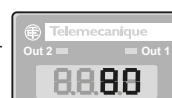
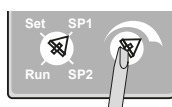
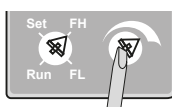
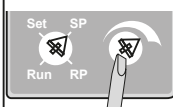

The change of rotary switch position memorizes the selected value.

**4 Adjust the low pressure threshold (Reset Point) or output 2 Set Point:**

Put the rotary switch on «RP» or «FL» or «SP2» position (depending on model). «RP» or «FL» or «SP2» and threshold value are alternatively displayed. SP2 means that you are adjusting the «Set Point» of the output 2.

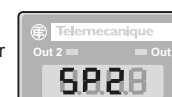
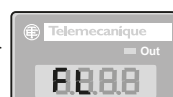
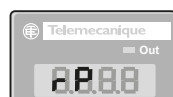
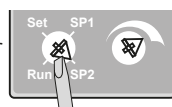
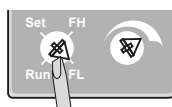
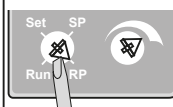

Then adjust the threshold value by turning the potentiometer.

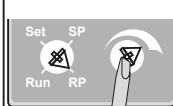

The change of rotary switch position memorizes the selected value.

**5 At the end of the setting:**

Put the rotary switch on «Run» position in order for the product to be operational. The fluid pressure is displayed. The potentiometer is no longer operational.

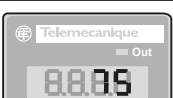

If the setting is final, it is recommended to enable the "Locking" function (see procedure in «Complementary setting»)

**Complementary setting:**

- **NO/NC output setting:** Factory default output setting is NO function.

To change to NC:



Turn the rotary switch to «Set» position.



Then turn the potentiometer to display the «nc» item.



Then turn back the switch on «Run» position. «NC» function is activated and the fluid pressure is displayed.

To come back to NO function, use the same process but select the «no» item.

- **Locking / unlocking function:** In order to avoid any mis-adjustment afterward by an unauthorized person, the product can be locked.

**Locking**

To activate the locking function



Turn the rotary switch to «Set» position.



Then turn the potentiometer to display the «Loc» item.



Then turn back the switch on «Run» position. The product is locked and the fluid pressure is displayed.

- When the locking function is activated, no adjustment is possible. Nevertheless you can read the adjusted values by turning the rotary switch in «SP\*» position (\*: Can be SP1, SP2, SP, rP, FH or FL depending of the model).
- If the operator turns the potentiometer, «Loc» is alternately displayed with the threshold value.

**Unlocking**

To unlock the product and to allow adjustment again



Turn the rotary switch to «Set» position. «PaSS» is displayed, requesting for a password.



Then turn the potentiometer to display the key value «520».



Then turn back the switch on «Run» position. The fluid pressure is displayed.

Then the product is unlocked and can be adjusted again.