

Modicon M251 logic controllers

Catalogue
2014



How can you fit a 6000-page catalog in your pocket ?

Schneider Electric provides you with the complete set of industrial automation catalogs all on a handy USB key for PC or in an application for tablets



Digi-Cat, a handy USB key for PC



- > Convenient to carry
- > Always up-to-date
- > Environmentally friendly
- > Easy-to-share format

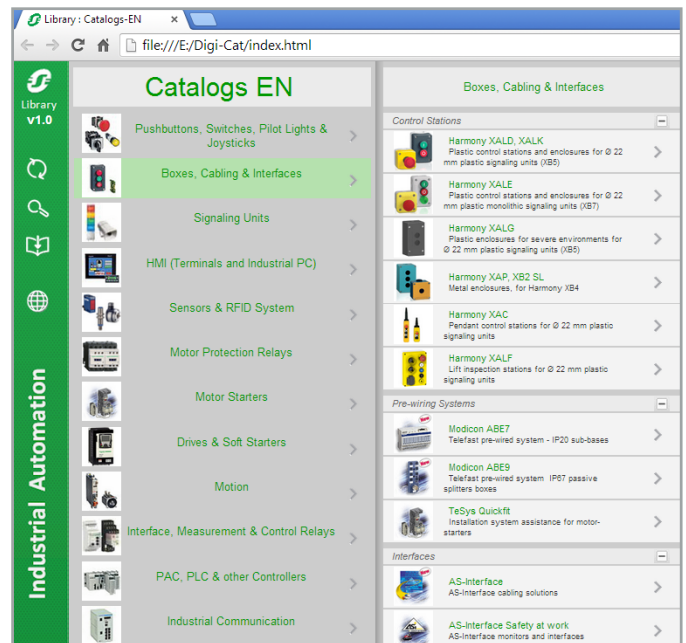

Contact your local representative to get your own Digi-Cat



e-Library, the app for tablets

If you have an iPad®:

- > Go to the App Store and search for e-Library
- > or scan the QR code



If you have an Android tablet:

- > Go to the Google Play Store™ and search for eLibrary
- > or scan the QR code

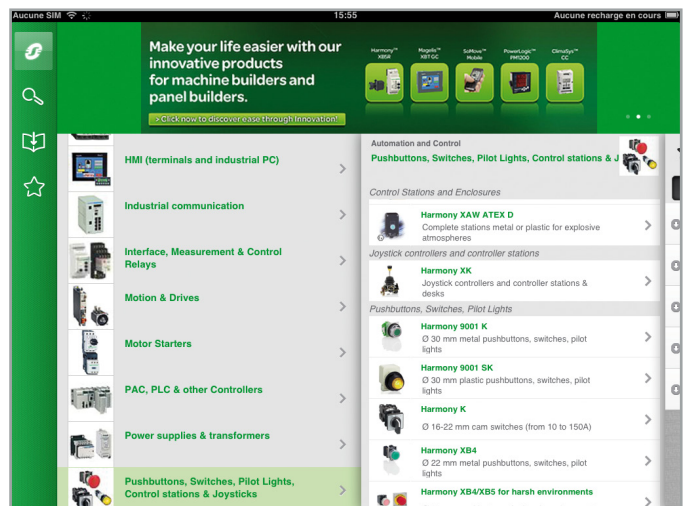

General contents

Modicon™ M251 logic controllers

■ Selection guide: Modicon™ M251 logic controllers	2
■ Presentation	
- Applications, key features	4
- Embedded connection	4
- Options	5 and 6
- Communication modules	5
- I/O extensions with Modicon TM3 expansion modules	7
- Embedded communication	8 and 9
■ Description	
- Modicon M251 logic controllers	10
■ References	
- Modicon M251 logic controllers	11
- Options	11
- Separate parts, software, cordsets	11

Modicon TM4 communication modules

■ Ethernet switch module	
- Presentation, description	12
- References	13
■ Profibus DP slave module	
- Presentation, description	12
- References	13

Communication bus

■ Serial links (Modbus protocols, character mode)	
- Presentation, description	14
- References	14 and 15
■ CANopen Architecture	
- Presentation, description	16
- References	17
■ Ethernet Modbus/TCP network	
- Presentation	18
- Description of Ethernet embedded ports on controllers	21
- Architecture	22
- References	23

Compatibility

■ Compatibility of Modicon TM2 expansion modules with Modicon M251 logic controllers	24
---	----

Products reference index	25
---------------------------------------	----

Applications	Control of modular machines on distributed architectures						
							
Supply voltage	24 V $\overline{\text{---}}$						
I/O expansion	<ul style="list-style-type: none"> ■ 7 Modicon TM3 expansion modules ■ 14 Modicon TM3 expansion modules with the use of bus expansion modules (transmitter and receiver) ■ Possible use of Modicon TM2 expansion modules with restrictions. 						
Embedded communication	<table border="1" style="width: 100%; border-collapse: collapse;"> <tr> <td style="background-color: #92d050; width: 150px;">Ethernet link</td> <td style="background-color: #cccccc;"> <ul style="list-style-type: none"> ■ Ethernet 1: 2 ports connected by a switch, "Machine" or "Factory" network (2 RJ 45 connectors) ■ Ethernet 2: 1 "fieldbus" Ethernet port (1 RJ 45 connector) <p>Modbus TCP (client & server), Modbus TCP slave, dynamic DHCP Client Configuration, Programming, download monitoring. Updated firmware, data exchange - NGVL and IEC VAR ACCESS, WEB server, IP Ethernet adapter SNMP network management.MIB2, FTP file transfer</p> </td> </tr> <tr> <td style="background-color: #92d050;">CANopen</td> <td style="background-color: #cccccc;">-</td> </tr> <tr> <td style="background-color: #92d050;">Serial link</td> <td style="background-color: #cccccc;"> <ul style="list-style-type: none"> ■ 1 serial link port (RJ 45), RS232/485 with +5 V supply </td> </tr> </table>	Ethernet link	<ul style="list-style-type: none"> ■ Ethernet 1: 2 ports connected by a switch, "Machine" or "Factory" network (2 RJ 45 connectors) ■ Ethernet 2: 1 "fieldbus" Ethernet port (1 RJ 45 connector) <p>Modbus TCP (client & server), Modbus TCP slave, dynamic DHCP Client Configuration, Programming, download monitoring. Updated firmware, data exchange - NGVL and IEC VAR ACCESS, WEB server, IP Ethernet adapter SNMP network management.MIB2, FTP file transfer</p>	CANopen	-	Serial link	<ul style="list-style-type: none"> ■ 1 serial link port (RJ 45), RS232/485 with +5 V supply
Ethernet link	<ul style="list-style-type: none"> ■ Ethernet 1: 2 ports connected by a switch, "Machine" or "Factory" network (2 RJ 45 connectors) ■ Ethernet 2: 1 "fieldbus" Ethernet port (1 RJ 45 connector) <p>Modbus TCP (client & server), Modbus TCP slave, dynamic DHCP Client Configuration, Programming, download monitoring. Updated firmware, data exchange - NGVL and IEC VAR ACCESS, WEB server, IP Ethernet adapter SNMP network management.MIB2, FTP file transfer</p>						
CANopen	-						
Serial link	<ul style="list-style-type: none"> ■ 1 serial link port (RJ 45), RS232/485 with +5 V supply 						
Options	<table border="1" style="width: 100%; border-collapse: collapse;"> <tr> <td style="background-color: #92d050; width: 150px;">Communication modules</td> <td style="background-color: #cccccc;"> <ul style="list-style-type: none"> ■ 1 Ethernet port Modicon TM4 module with switch function and 4 integrated ports ■ 1 Modicon TM4 module for slave Profibus DP link </td> </tr> </table>	Communication modules	<ul style="list-style-type: none"> ■ 1 Ethernet port Modicon TM4 module with switch function and 4 integrated ports ■ 1 Modicon TM4 module for slave Profibus DP link 				
Communication modules	<ul style="list-style-type: none"> ■ 1 Ethernet port Modicon TM4 module with switch function and 4 integrated ports ■ 1 Modicon TM4 module for slave Profibus DP link 						
Mounting	Mounting on \perp symmetrical rail or panel						
Software programming	With SoMachine software						
Controller type	TM251MESE						
Pages	11						

Control of modular machines on distributed architectures		
		
24 V $\overline{\text{---}}$		
<ul style="list-style-type: none"> ■ 7 Modicon TM3 expansion modules ■ 14 Modicon TM3 expansion modules with the use of bus expansion modules (transmitter and receiver) ■ Possible use of Modicon TM2 expansion modules with restrictions. 		
<ul style="list-style-type: none"> ■ Ethernet: 2 ports connected by a switch, "Machine" or "Factory" network (2 RJ 45 connectors) <p>Modbus TCP (client & server), Modbus TCP slave, dynamic DHCP Client Configuration, Programming, download monitoring. Updated firmware, data exchange - NGVL and IEC VAR ACCESS, WEB server, IP Ethernet adapter SNMP network management.MIB2, FTP file transfer</p>		
<ul style="list-style-type: none"> ■ 1 master CANopen port (1 x 9-way SUB-D connector) 		
<ul style="list-style-type: none"> ■ 1 serial link port (RJ 45), RS232/485 with +5 V supply 		
<table border="1" style="width: 100%; border-collapse: collapse;"> <tr> <td style="background-color: #92d050; width: 150px;">Communication modules</td> <td style="background-color: #cccccc;"> <ul style="list-style-type: none"> ■ 1 Ethernet port Modicon TM4 module with switch function and 4 integrated ports ■ 1 Modicon TM4 module for slave Profibus DP link </td> </tr> </table>	Communication modules	<ul style="list-style-type: none"> ■ 1 Ethernet port Modicon TM4 module with switch function and 4 integrated ports ■ 1 Modicon TM4 module for slave Profibus DP link
Communication modules	<ul style="list-style-type: none"> ■ 1 Ethernet port Modicon TM4 module with switch function and 4 integrated ports ■ 1 Modicon TM4 module for slave Profibus DP link 	
Mounting on \perp symmetrical rail or panel		
With SoMachine software		
TM251MESD		
11		

Compatibility of offers

Modicon M251 logic controllers

- > Modicon TM3 expansion modules
- > Modicon TM2 expansion modules
- > Modicon TM4 communication modules
- > SoMachine software



TM251MESE



TM251MESC



QRcode example :
QRcode for access to the technical data sheet for
TM251MESE logic controller



SoMachine software

Presentation

Applications

Modicon M251 controllers offer an innovative, high-performance solution in the field of modular machines and distributed architectures.

Thanks to their compact dimensions, they can optimize the size of wall-mounted and floor standing control system enclosures.

Since Modicon M251 controllers have no embedded I/O, field devices such as variable speed drives and remote I/O are connected on either the CanOpen bus or the Ethernet network.

The Ethernet ports embedded in each M251 controller offer FTP and web server services, making it easy to integrate control system architectures and remote control of machines using applications for smartphones, tablets and PCs.

- The wealth of embedded functions minimizes the cost of the machine:
 - Functions embedded in the controller: Modbus serial link, USB port dedicated to programming, CANopen fieldbus for distributed architectures, advanced position control functions (high-speed counters and pulse train outputs for servo motor control).
 - Functions embedded in the Modicon TM3 expansion: functional safety modules, motor-starter control module and remote expansion system.
 - Functions embedded in the Modicon TM4 communication modules.
- The processing power and the memory size of M251 controllers are ideal for targeting performance applications.
- The application is created quickly thanks to the intuitive nature and power of the SoMachine programming software. It also makes it easy to retrieve existing applications in the Modicon M221, M238 and M258 ranges automatically, maximizing use of the investment already made.

Key features

- Both Modicon M251 logic controllers come in an identical format (w x h x d): 54 x 90 x 95 mm (2.13 x 3.54 x 3.74 in).
- Modicon M251 controllers have no embedded I/O but can be combined with Modicon TM3 expansion modules.
- Each M251 controller has a Run/Stop switch.
- Each M251 controller has a slot for an SD (Secure Digital) memory card.
- Each M251 controller has a QR code for direct access to its technical documentation.

Embedded connection

M251 logic controllers have up to 5 integrated communication ports.

- The **TM251MESE** controller has the following embedded features:
 - an "Ethernet 1" network (1) with 2 RJ 45 ports connected by an internal switch, this network being mainly for communication between machines or to your factory network.
 - an "Ethernet 2" network (1) with an RJ 45 port, optimized for connecting field devices (variable speed drives, distributed I/O, etc.) by means of the Ethernet I/O scanner service. This port can also be connected to a factory network.
- The **TM251MESC** controller has the following embedded features:
 - an "Ethernet" network (1) with 2 RJ 45 ports connected by an internal switch, this network being mainly for communication between machines or to your factory network.
 - a master CANopen port for connecting field devices (variable speed drives, distributed I/O, etc.).
- Moreover, both these M251 logic controllers incorporate:
 - a serial link port.
 - a programming port.

(1) Ethernet with embedded Web server function

Processing power

- Execution speed: 22 ns/boolean instructions.
- Program: 128 K boolean instructions.
- DualCore processor.
- RAM: 64 MB.
- Flash memory: 128 MB.

Programming

Modicon M251 logic controllers are programmed with the SoMachine software (see on our website www.schneider-electric.com).

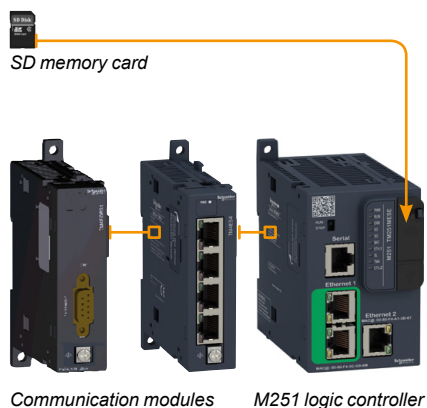

Options for Modicon M251 controllers

Memory card

The **TMASD1** SD memory card, with 512 MB capacity, is available for:

- application backup.
- program transfer.
- data logging.
- firmware updating.

Communication modules (1)

2 communication module models are available:

- The **TM4ES4** Ethernet switch module
- The **TM4PDPS1** Profibus DP slave module

Modicon TM4 communication modules are assembled by simple interlocking on the left-hand side of the controllers and a bus expansion connector is used to distribute data and the power supply.

Up to 3 communication modules can be added on the left of M251 logic controllers.

See page 12.

■ Ethernet switch module

- The **TM4ES4** module is a 4-port Ethernet interface (10/100 Mbps, MDI/MDIX).
- Clipped onto the left-hand side of a Modicon M251 controller, it consists of an autonomous switch with 4 ports supplied by the Modicon M251 controller.

■ PROFIBUS DP slave module

- The **TM4PDPS1** communication module can be used to configure a Master connection on the PROFIBUS DP bus.

(1) For association rules between Modicon TM4 communication modules and Modicon M251 logic controllers (see page 12).

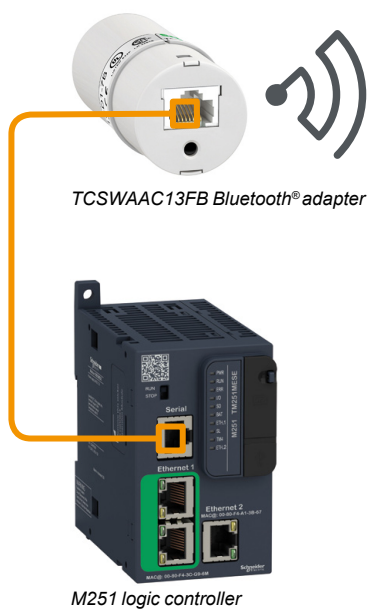

Communication option for link Bluetooth® wireless link

The Bluetooth® wireless link enables complete freedom of movement within a radius of 10 m (32.808 ft.) around the controller.

For its M251 controllers Schneider Electric offers the **TCSWAAC13FB** Bluetooth® adapter to perform the following functions:

- commissioning
- monitoring

Modicon M251 logic controllers

I/O extensions with Modicon TM3 expansion modules

I/O extensions with Modicon TM3 modules

Modicon TM3 expansion modules (see on our website www.schneider-electric.com)

Modicon M251 logic controllers have no embedded I/O, yet can still take Modicon TM3 expansion modules for connecting sensors and actuators locally:

- digital I/O modules for creating configurations with up to 224 digital I/O.
- analog I/O modules for creating configurations with up to 114 analog I/O, to receive the signals from, for example, position, temperature, and speed sensors and also capable of controlling variable speed drives or any other device with a current or voltage input.
- expert modules for controlling 4 TeSys motor-starters, connected with RJ 45 cordsets to simplify wiring the control section.
- Functional Safety modules that simplify the wiring and can be configured in the SoMachine software.

In addition, the Modicon TM3 expansion system is flexible due to the possibility of remotely locating some of the Modicon TM3 modules in the floor standing enclosure or another wall-mounted enclosure, up to 5 meters (16.404 ft.) away, thanks to the use of a bus expansion system.

The Modicon TM3 expansion system is common to the whole range of Modicon M221, M241 and M251 logic controllers, meaning that applications can be upgraded without changing extension.

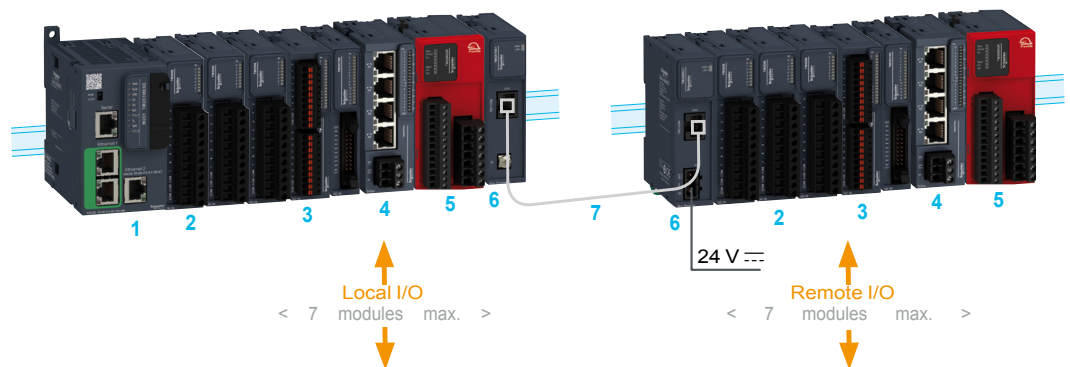

- 1 M251 logic controller.
- 2 Modicon TM3 digital I/O modules.
- 3 Modicon TM3 analog I/O modules ⁽¹⁾.
- 4 Modicon TM3 expert module: for controlling TeSys motor-starters.
- 5 Modicon TM3 functional safety modules.
- 6 Modicon TM3 bus expansion modules (transmitter and receiver).
- 7 Modicon TM3 bus expansion cordset.

(1) Compatibility of expansion module offers: most Modicon TM2 expansion modules can be used with M251 logic controllers. Nonetheless, inserting a Modicon TM2 expansion module in a configuration can increase the expansion module execution times by as much as a few milliseconds. The compatibility of Modicon TM2 expansion modules with M251 logic controllers is described in detail on page 24.

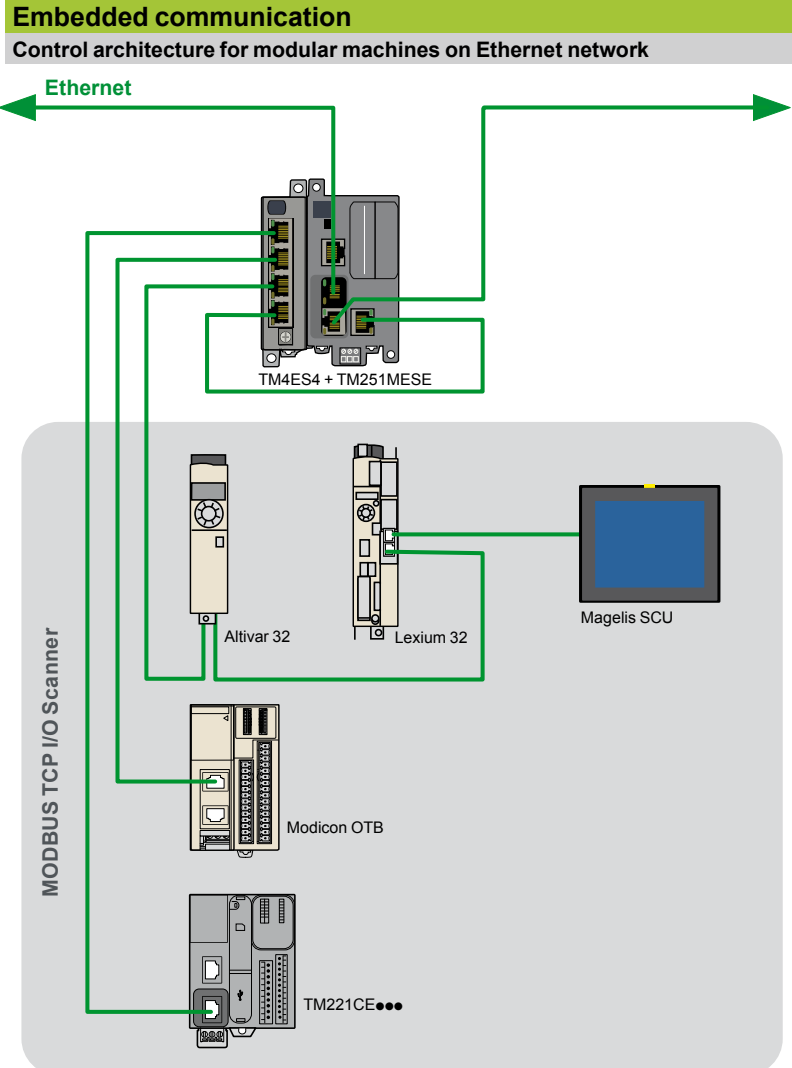

M251 controllers have 2 embedded Ethernet ports connected by an RJ 45 switch (10/100 Mbps, MDI/MDIX) with the Modbus TCP (Client/Server), Ethernet IP (adapter), UDP, TCP, SNMP and SoMachine on Ethernet protocols. These ports are mainly for communication between machines or to your factory network. These ports are marked "Ethernet" or "Ethernet 1".

- ❑ M251 controllers each have an embedded web server and FTP server. As well as the default address based on the MAC address, a controller IP address can be assigned via a DHCP server or via a BOOTP server.
- ❑ Ethernet ports also offer the same upload/download, update and debug functions as the programming port (USB mini-B) when the controller is supplied with power.
- ❑ A firewall allows to filter IP addresses accessing the controller and to lock each communication protocol.
- ❑ **TM251MESE** controllers have, in addition to the two embedded "Ethernet 1" ports, an embedded "Ethernet 2" Ethernet port optimized for connecting RJ 45 type field devices (variable speed drives, distributed I/O, etc.), with Ethernet Modbus TCP I/O scanner, Ethernet Modbus TCP (Client/Server), Ethernet IP (adapter), UDP, TCP, SNMP and SoMachine protocols.

Cordsets and connection accessories for Ethernet network (see page 18).

Embedded communication (continued)

Control architecture for modular machines on CANopen bus

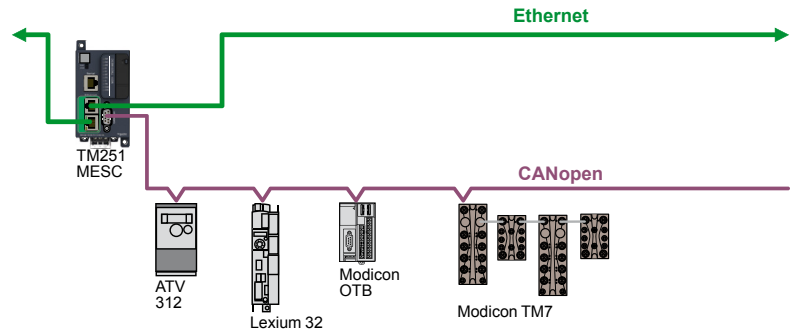

TM251MESC controllers have an embedded master CANopen port.

- The link can be configured between 20 Kbps and 1 Mbps and supports up to 63 slaves with 252 TPDO and 252 RPDO.
- CANopen-based architectures can be used to distribute I/O modules as close to the sensors and actuators as possible, thus reducing wiring costs and times, and to communicate with different devices such as variable speed drives, servo drives, etc.
- The CANopen configurator is integrated in the SoMachine software and can also be used to import standard description files in EDS format.

CANopen cordsets and connection accessories: see page 16.

Serial link

Each M251 controller has an embedded serial link that can be configured as RS 232 or RS 485.

In addition, a 5 V/200 mA power supply is available on the RJ 45 connector which allows the use of a Magelis **XBTN** or **XBTRT** HMI, the **TCSWAAC13FB** Bluetooth® communication adapter or other devices.

Embedded in both links are the two main protocols used in the market:

- Modbus ASCII/RTU Master or Slave.
- Character string (ASCII).

Connection cables and accessories for serial link: see page 14.

Programming port with power off charging function

The programming port, equipped with a mini-B USB connector, is embedded on each M251 controller; it is dedicated to communication with a PC equipped with SoMachine for:

- programming
- debugging
- maintenance

In addition, it offers the ability to upload an application program or update the firmware without the controller being supplied with power from another source.

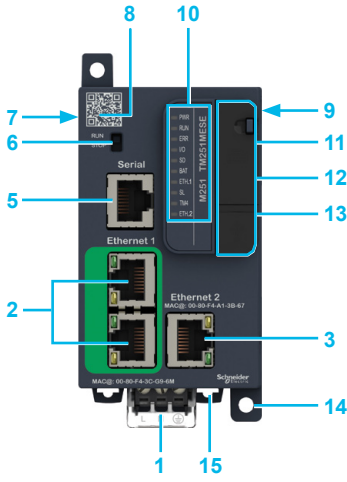

TM251MESE controller

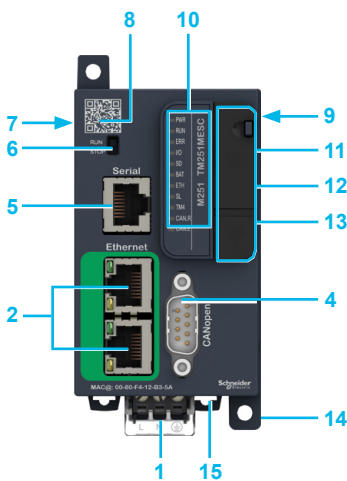

TM251MES C controller

Description

M251 controllers

- 1 Removable screw terminal block, 3 terminals for connecting the 24 V $\bar{\bar{}}$ power supply.
- 2 Two RJ 45 connectors connected by an internal switch for “Machine” or “Factory” Ethernet network, with exchange rate and activity LED.
- 3 On **TM251MESE** controller: RJ 45 connector for Ethernet 2 network, “fieldbus” with exchange rate and activity LED.
- 4 On **TM251MES C** controller: a connector for linking to the CANopen bus (9-way SUB-D).
- 5 SL serial link port (RS 232 or RS 485): RJ 45 connector.
- 6 Run/Stop switch.
- 7 TM4 bus connector: communication bus for linking to TM4●●● communication modules.
- 8 Controller technical documentation QR code.
- 9 Modicon TM3 bus connector for linking to a Modicon TM3 expansion module.
- 10 LED display block showing: the status of the controller and its components (battery, SD memory card), the status of the embedded communication ports (Ethernet 1 and 2, CANopen, serial link).

Behind a cover 11, 12, 13

- 11 Slot for the SD memory card.
- 12 Backup battery slot.
- 13 USB mini-B connector, marked “Prg. Port”, for connecting a programming terminal.
- 14 Lugs for screw mounting on panel.
- 15 Clip for locking on \perp symmetrical rail.

Characteristics of M251 logic controllers

Conformity

- Certifications
 - CE, cULus Listing Mark, C-Tick, EAC, LR, ABS, DNV and GL (1).

Standards

- IEC/EN 61131-2 (Edition 2 2007), UL 508 (UL 61010-2-201), ANSI/ISA 12.12.01-2007, CSA C22.2 No. 213, No.142, E61131-2 and IACS E10.

Environment characteristics

- Ambient operating temperature: - 10...+ 55°C (+14...+ 131°F).
- Storage temperature: - 40...+ 70°C (- 40...+ 158°F).
- Relative humidity: 5...95% (non-condensing).
- Operating altitude: 0...2,000 m (0...6,561 ft).
- Storage altitude: 0...3,000 m (0...9,842 ft).
- Immunity to mechanical stress:
 - For 1131: 5...8.4 Hz (amplitude 3.5 mm/0.138 in.); 8.4...150 Hz (acceleration 1 g).
 - For merchant marine: 5...13.2 Hz (amplitude 1.0 mm /0.039 in.); 13.2...100 Hz (acceleration 0.7 g).

Supply characteristics

- 24 V $\bar{\bar{}}$ power supply.
- Voltage limit (including ripple): 19.2...28.8 V $\bar{\bar{}}$.
- Immunity to micro-cuts (class PS-2): 10 ms.
- Max. consumption: 45 W.

(1) LR, ABS, DNV and GL marine certifications: pending.

Modicon M251 logic controllers

M251 logic controllers, options, separate parts, software, cordsets



TM251MESE



TM251MESC



TMASD1

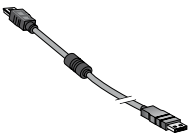

TCSXCNAMUM3P

References

Modicon M251 logic controllers (1)

Description	Embedded communication ports				Reference	Weight kg/ lb
	Ethernet 1 "Machine" or "Factory" (RJ 45)	Ethernet 2 "Fieldbus" (RJ 45)	Master CANopen (9-way SUB-D)	Serial link (RJ 45)		
24 V \square power supply						
M251 logic controllers	2 (connected by a switch)	1	–	1	TM251MESE	0.220/ 0.485
	2 (connected by a switch)	–	1	1	TM251MESC	0.220/ 0.485

Options for Modicon M251 logic controllers

Description	Details	Reference	Weight kg/ lb
SD memory card	Application backup and program transfer Capacity: 256 MB	TMASD1	0.004/ 0.009

Replacement parts

Description	Details	Reference	Weight kg/ lb
Set of power supply terminal blocks	8 removable screw terminal blocks	TMAT2PSET	0.127/ 0.280
Backup battery	The battery supplied with each controller is not available as a separate element Schneider reference. If necessary spare parts, use only a Panasonic BR2032 battery type.		

Programming software

Description	Used for	Reference
SoMachine software	M251 logic controllers	See on our website www.schneider-electric.com

Expansion modules

Description	Used for	Reference
Modicon TM3 expansion modules	M251 logic controllers	See on our website www.schneider-electric.com

Communication modules

Description	Details	Reference
Modicon TM4 communication modules	Ethernet port module , Profibus DP slave module	See page 12

Cordsets

Description	Use from	To	Length m/ft	Reference	Weight kg/ lb
Programming cables	PC USB port	USB mini-B port on M251 controllers	3/ 0.98	TCSXCNAMUM3P (3)	0.065/ 0.143
			1,8/ 5,90	BMXXCAUSBH018	0.065/ 0.143

(1) M251 controllers are supplied with:

- a removable screw terminal block for connecting the power supply.
- a BR2032 button cell backup battery.

(2) Each M251 logic controller has an embedded USB mini-B programming port.

(3) Unshielded cable without grounding. To be used only for temporary connections. For permanent connections, use the reference BMXXCAUSBH018 programming cable.

Compatibility of offers

Modicon TM4 communication modules

- > Modicon M241 logic controllers
- > Modicon M251 logic controllers



Presentation

Applications

The Modicon TM4 offer enhances the connectivity for Modicon M241 and M251 logic controllers.

Two communication module models are available:

- The **TM4ES4** Ethernet switch module (offering, only on controllers without embedded Ethernet, an Ethernet connection with 4 ports).
- The **TM4PDPS1** Profibus DP slave module.

■ Ethernet switch module

The **TM4ES4** module is a 4-port Ethernet interface (10/100 Mbps, MDI/MDIX) with the following protocols: Modbus TCP (Client/Server), Ethernet IP (adapter), UDP, TCP, SNMP and SoMachine.

- The **TM4ES4** module is ready for use as soon as it is connected to the communication bus of M241 controllers.
- This module is used to add the Ethernet function to TM241C24● and TM241C40● controllers without embedded Ethernet port while offering the additional functionality of an Ethernet switch.
- When connected to logic controllers with embedded Ethernet port type TM241CE24●●●, TM241CE40●●●, or on a TM251MES● controller it is a 4 port stand-alone switch: the communication between the TM4ES4 module and the Modicon M241 and M251 controllers is not done automatically by the bus connector.

■ Profibus DP slave module

The **TM4PDPS1** communication module can be used to configure a slave connection on the Profibus DP bus.

Association rules

Up to 3 communication modules (total) can be added on the left of M241 and M251 logic controllers, in order to increase their possibilities of connection to the Ethernet and Profibus networks.

- On controllers without embedded Ethernet port (TM241C24●●● and TM241C40●●●): it is possible to add one **TM4ES4** module with the Ethernet port function and two **TM4ES4** modules with the switch function while respecting the maximum number of 3 **TM4** modules .
- On controllers with embedded Ethernet port (TM241CE●● and TM251●●●): it is possible to add 3 modules **TM4ES4** with switch function while respecting the number of 3 **TM4** modules.
- **TM4** communication modules are assembled by simple interlocking on the left-hand side of the controllers and a bus expansion connector is used to distribute data and the power supply.

Description

■ TM4ES4 Ethernet switch module

- 1 Power on LED indicator.
- 2 Bus connector (one on each side).
- 3 4 RJ 45 connectors for Ethernet network, with exchange rate and activity LED.
- 4 Screw terminal for the functional earth (FE) connection.
- 5 Locking clip on \perp symmetrical rail.

■ TM4PDPS1 Profibus DP slave module

- 1 Power on LED indicator.
- 2 Bus connector (one on each side).
- 3 9-way SUB-D connector for connection to the Profibus DP bus.
- 4 Screw terminal for the functional earth (FE) connection.
- 5 Locking clip on \perp symmetrical rail.

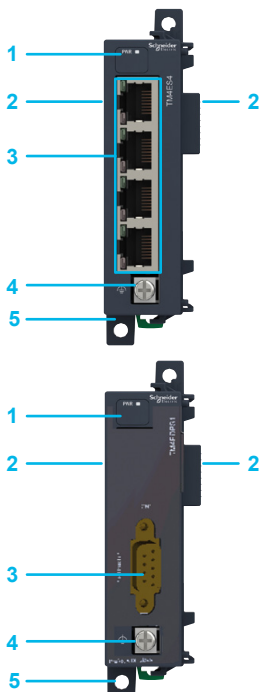

Modicon M251 logic controllers

Modicon TM4 communication modules

For Modicon M251 logic controllers



TM4ES4



TM4PDPS1

References

Options for Modicon M241 and M251 logic controllers

Designation	Description	Reference	Weight kg/lb
Communication modules	Multi-port Ethernet interface equipped with four RJ 45 connectors (10/100 Mbps, MDI/MDIX)	TM4ES4 (1)	0.110/ 0.243
	Slave connection on the Profibus DP bus, equipped with a 9-way SUB-D connector	TM4PDPS1	0.110/ 0.243

(1) Can be used as an Ethernet port or as a standalone switch according to controller model and configuration.

Modicon M251 logic controllers

Serial links

Modbus protocols, character mode

Presentation

RS 232/RS 485 serial links offer a simple solution to the communication needs of machines.

Modbus and ASCII standard communication protocols are used to connect numerous equipment items such as: HMIs, printers, energy meters, variable speed drives, motor starters, remote I/O (RIO), etc.

Description

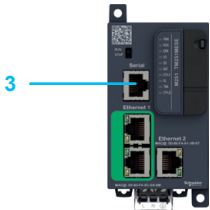

Modicon **M241** logic controllers have the following on their upper surface:

- 1 A "Serial 1" serial link port with an RJ45 connector delivering a 5 V/200 mA power supply which allows the use of a Magelis HMI, the Bluetooth® communication adaptor or other devices.
- 2 A 2nd "Serial 2" serial link port (with connection on screw terminals).

Controller Type	Embedded Ports	
	"Serial 1" port, RJ45 connector	"Serial 2" port, connection on screw terminals
TM241 ●●●●	RS 232/RS 485 with 5V (200 mA) power supply for HMI or Bluetooth communication adaptor (item 1)	RS 485 (item 2)

Modicon **M251** logic controllers have on their front a serial link port with an RJ45 connector delivering a 5 V/200 mA power supply which allows the use of a Magelis HMI, the Bluetooth® communication adaptor or other devices.

- 3 A serial link port (RJ 45 connector (RS 232 or RS 485)).

Modbus serial link wiring system

Non-isolated bus

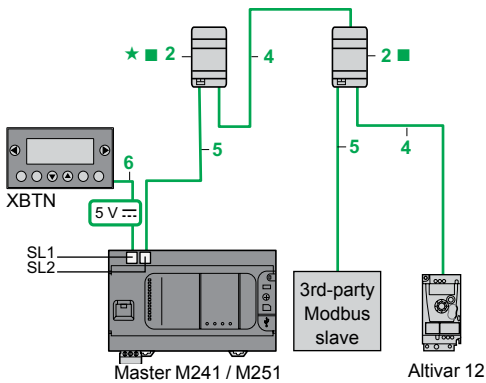

Isolated bus (recommended for bus > 10 m (32.808 ft))

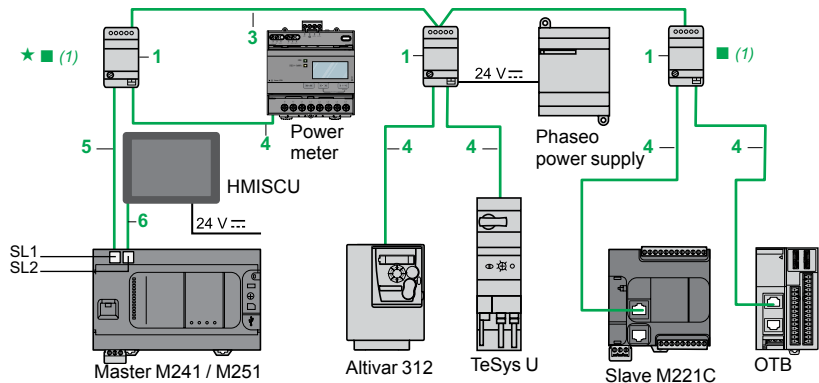

- Total length of cables between M241/M251 and ATV12: ≤ 30 m (98.425 ft)
- Length of cable 4: ≤ 10 m (32.808 ft)
- ★ Line polarization active. ■ Line termination

- Total length of cables between isolation boxes 1: ≤ 1000 m (3280.840 ft)
- Length of drop cables 4 or 5: ≤ 10 m (32.808 ft)
- ★ Line polarization active. ■ Line termination
- (1) Box powered by the logic controller.

References



TWDXCAISO TWDXCAT3RJ

Tap-off and adaptor components for RS 485 serial link

Designation	Description	Item	Length m/ft	Unit reference	Weight kg/lb
T-junction and isolation box Screw terminals for trunk cable 2 x RJ45 for tap-off	<input type="checkbox"/> Isolation of the RS 485 link (1) <input type="checkbox"/> Line termination (RC 120 Ω, 1nF) <input type="checkbox"/> Line pre-polarization (2 R 620 Ω) <input type="checkbox"/> 24 V power supply (screw terminals) or 5 V power supply (via RJ45) <input type="checkbox"/> Mounting on 35 mm (1.378 in.)	1	–	TWDXCAISO	0.100/ 0.220
T-junction box 1 x RJ45 for trunk cable 2 x RJ45 for tap-off	<input type="checkbox"/> Line termination (RC 120 Ω, 1nF) <input type="checkbox"/> Line pre-polarization (2 R 620 Ω) <input type="checkbox"/> Mounting on 35 mm (1.378 in.)	2	–	TWDXCAT3RJ	0.080/ 0.176

(1) Line isolation recommended for line distances > 10 m (32.808 ft).



LU9GC3



TSXSCA50



XGSZ24

References (continued)

Designation	Description	Item	Length m/ft	Reference	Weight kg/ lb
Tap-off and adaptor components for RS 485 serial link					
Modbus splitter box	<input type="checkbox"/> Mounting on 35 mm (1.378 in.) \perp , on plate or panel <input type="checkbox"/> Screw terminals for trunk cable <input type="checkbox"/> 10 x RJ45 for tap-off	–	–	LU9GC3	0.500/ 1.102
T-junctions	1 integrated cable with RJ45 connector for tap-off dedicated to Altivar variable speed drive	–	0.3/ 0.98	VW3A8306TF03	–
	2 x RJ45 for trunk cable	–	1/ 3.28	VW3A8306TF10	–
Passive T-junction box	<input type="checkbox"/> 1-channel line extension and tap-off on screw terminals <input type="checkbox"/> Line termination	–	–	TSXSCA50	0.520/ 1.146
RS 232C/RS 485 line converter	<input type="checkbox"/> Max. data rate 19.2 Kbps, No modem signals <input type="checkbox"/> 24 V $\overline{\text{---}}$ /20 mA power supply <input type="checkbox"/> Mounting on 35 mm (1.378 in.)	–	–	XGSZ24	0.100/ 0.220
Cables and cordsets for RS 232 serial link					
RS 485 double shielded twisted pair trunk cables	Modbus serial link, supplied without connector	3	100/ 328.08	TSXCSA100	5.680/ 11.023
			200/ 656.16	TSXCSA200	10.920/ 24.074
			500/ 1640.42	TSXCSA500	30.000/ 66.139
Modbus RS 485 cordsets	2 x RJ45 connectors	4	0.3/ 0.98	VW3A8306R03	0.030/ 0.066
			1/ 3.28	VW3A8306R10	0.050/ 0.110
			3/ 9.84	VW3A8306R30	0.150/ 0.331
	1 x RJ 45 connector and 1 end with flying leads	5	1/ 3.28	TWDXCAFJ010	0.060/ 0.132
			3/ 9.84	VW3A8306D30	0.150/ 0.331
Cordsets: used from M241 (SL1), M251 controllers to Magelis HMI	2 x RJ45 connectors Compatible with:	6	2.5/ 8.202	XBZT9980	0.230/ 0.507
	<input type="checkbox"/> Com Port 1 on XBTN200/N400/R400/RT500 (1) <input type="checkbox"/> Com Port 1 on XBTRT511 and HMISTO/STU/SCU <input type="checkbox"/> Com Port 2 on XBTGT2●●0...7●●0 and HMIGTO	6	10/ 32.81	XBZT9982	–
	1 x RJ45 connector and 1 x 25-way SUB-D connector Compatible with:	–	2.5/ 8.20	XBZT9938	0.210/ 0.463
	<input type="checkbox"/> Com Port 1 on XBTN410/N410 and XBTR410/R411	–	2.5/ 8.20	XBZT9008	–
	1 x RJ45 connector and 1 x 9-way SUB-D connector Compatible with:	–	2.5/ 8.20	XBZT9008	–
	<input type="checkbox"/> Com Port 1 on XBTGT2●●0...7●●0	–	2.5/ 8.20	XBZT9008	–
Cordsets: used from M241 (SL2) controllers to Magelis HMI	1 x RJ45 connector and stripped wires Compatible with:	–	3/ 9.84	VW3A8306D30	0.150/ 0.331
	<input type="checkbox"/> Com Port 1 on XBTRT511 and HMISTO/STU/SCU <input type="checkbox"/> Com Port 2 on XBTGT2●●0...7●●0 and HMIGTO	–	3/ 9.84	VW3A8306D30	0.150/ 0.331
Line end adapter Sold in packs of 2	For RJ45 connector R = 120 Ω , C = 1 nf	–	–	VW3A8306RC	0.200/ 0.441
Cordsets for RS 232 serial link					
Cordset for DTE terminal (printer) (2)	Serial link for Data Terminal Equipment (DTE) 1 x RJ45 connector and 1 x 9-way female SUB-D connector	–	3/ 9.84	TCSMCN3M4F3C2	0.150/ 0.331
Cordset for DCE terminal (modem, converter)	Serial link for point to point device (DCE) 1 x RJ45 connector and 1 x 9-way male SUB-D connector	–	3/ 9.84	TCSMCN3M4M3S2	0.150/ 0.331

(1) If the terminal is equipped with a 25-way SUB-D connector, you will also need to order the **TSXCTC07** 25-way female / 9-way male SUB-D adaptor.

(2) Can only be connected to the controller SL or SL1 ports in order to supply the Magelis terminal with power.

Presentation

Schneider Electric has selected CANopen for its machines and installations because of its wealth of functions and its resulting benefits in the automation world. This decision was based on the general acceptance of CANopen, and the fact that CANopen products are increasingly used in control system architectures. CANopen is an open network supported by more than 400 companies worldwide, and promoted by CAN in Automation (CiA).

CANopen conforms to standards EN 50325-4 and ISO 15745-2.

Schneider Electric is heavily involved in working groups, which are important for machine and installation architectures, systems and products.

- The bus uses a double shielded twisted pair on which, with Modicon M241 and Modicon M251 logic controllers, a maximum of 63 devices are connected by daisy-chaining or by tap junctions.
- Each end of the bus must be fitted with a line terminator. On M241 controllers, this line terminator is already integrated on the master side and can be disconnected using a switch located next to the CAN connector.

CANopen port on M241 and M251 controllers

Type	M241: screw terminals M251: 9-way SUB-D							
Standards	DS 301 V4.02, DR 303-1							
Class	M10							
Data rate								
Max. length (m / ft.)	20/ 65.62	40/ 131.23	100/ 328.08	250/ 820.21	500/ 1640.42	1000/ 3280.84	2500/ 8202.1	5000/ 16404.2
Data rate (Kbps)	1000	800	500	250	125	50	20	10
Number of slaves	63 slaves max. with limit of: 252 RPDOs and 252 TPDOs							

Description

CANopen port on M241 and M251 controllers

The underside of Modicon **TM241CEC●●●** logic controllers has:

- 1 a connector for linking to the CANopen bus (screw terminals).
- 2 a CANopen line termination switch.

The front of the Modicon **TM251MES** logic controller has:

- 3 a connector for linking to the CANopen bus (9-way SUB-D).



1
2
TM241CEC●●● controllers

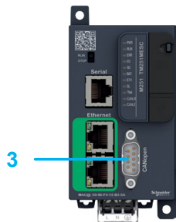

3
TM251MES controller

CANopen connection architecture

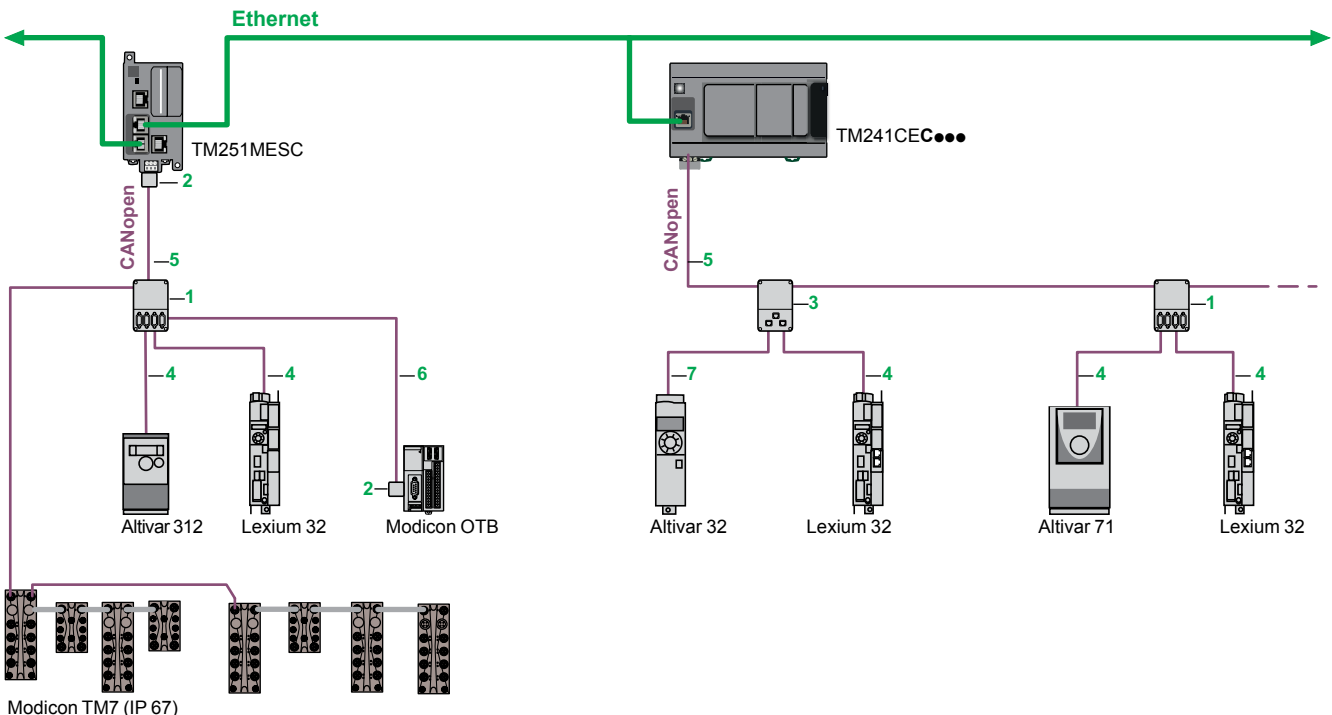

References

CANopen standard taps and connectors

Designation	Description	Item	Length m/ft	Unit reference	Weight kg/lb
IP20 CANopen tap junction	Line termination : 4 SUB-D ports. Screw terminals for connecting the trunk cables	1	–	TSXCANTDM4	0.196/0.432
IP 20 CANopen connectors 9-way female SUB-D Line end adapter switch	Right-angle	2	–	TSXCANKCDF90T	0.046/0.101
	Straight (for connection to the Altivar IMC integrated controller card)	2	–	TSXCANKCDF180T	0.049/0.108
	Right-angle with 9-way SUB-D for connecting a PC or diagnostic tool	2	–	TSXCANKCDF90TP	0.051/0.112
IP 20 CANopen tap junction for Altivar and Lexium 32	2 RJ45 ports	3	–	VW3CANTAP2	0.250/0.551
Daisy chain taps	Equipped with: □ 2 sets of spring terminals for daisy chain connection of the CANopen bus □ 1 preassembled cordset with RJ45 connector for connecting the drive	–	0.6/1.97	TCSCTN026M16M	–
	Equipped with: □ 2 RJ45 connectors for daisy chain connection of the CANopen bus □ 1 preassembled cordset with RJ45 connector for connecting the drive	–	0.3/0.98	TCSCTN023F13M03	–
CANopen line terminators	For RJ45 connector Sold in lots of 2	–	–	TCSCAR013M120	–
	For screw terminal connector Sold in lots of 2	–	–	TCSCAR01NM120	–



TSXCANTDM4

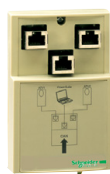

VW3CANTAP2

TSXCAN
KCD F90TTSXCAN
KCD F180TTSXCANKCD
F90TP

TCSCAR013M120



VW3CANA71

IP 20 standard cables and preassembled cordsets

Designation	Description	Item	Length m/ft	Unit reference	Weight kg/lb	
CANopen cables (2 x AWG 22 2 x AWG 24)	For standard environment (1), CE marking: Low smoke. Zero halogen. Non flame propagating (IEC 60332-1)	5	50/164.042	TSXCANCA50	4.930/10.869	
		100/328.08	TSXCANCA100	8.800/19.401		
		300/984.25	TSXCANCA300	24.560/54.146		
	For standard environment (1), UL certification, CE marking: Flame-retardant (IEC 60332-2)	5	50/164.04	TSXCANCB50	3.580/7.893	
		100/328.08	TSXCANCB100	7.840/17.284		
		300/984.25	TSXCANCB300	21.870/48.215		
CANopen preassembled cordsets	Cordsets with one 9-way female SUB-D connector at each end	For standard environment (1), CE marking: Low smoke. Zero halogen. Non flame propagating (IEC 60332-1)	6	0.3/0.98	TSXCANCADD03	0.091/0.201
			1/3.28	TSXCANCADD1	0.143/0.315	
			3/9.84	TSXCANCADD3	0.295/0.650	
		For standard environment (1), UL certification, CE marking: Flame-retardant (IEC 60332-2)	6	0.3/0.98	TSXCANCBDD03	0.086/0.190
			1/3.28	TSXCANCBDD1	0.131/0.289	
			3/9.84	TSXCANCBDD3	0.268/0.591	
Cordsets with one 9-way female SUB-D connector and one RJ45 connector	4	0.5/1.64	TCSCCN4F3M05T	0.100/0.220		
		1/3.28	TCSCCN4F3M1T	0.100/0.220		
		3/9.843	VW3M3805R010 (2)	0.100/0.220		
		1/3.281	VW3M3805R030 (2)	0.300/0.661		
		3/9.84	TCSCCN4F3M3T	0.160/0.353		
		0.5/1.64	TLACDCBA005	0.100/0.220		
Cordsets with two 9-way SUB-D connectors, one male and one female	–	1.5/4.92	TLACDCBA015	0.120/0.265		
		3/9.84	TLACDCBA030	0.190/0.419		
		5/16.40	TLACDCBA050	0.350/0.772		
		0.3/0.984	VW3CANCARR03	0.100/0.220		
Preassembled cordsets with one RJ 45 connector at each end	7	1/3.281	VW3CANCARR1	0.100/0.220		
		–	–	–		
Adapter for Altivar 71 drive	One RJ45 connector at each end	–	–	VW3CANA71	0.100/0.220	

Taps and IP 67 accessories

Please consult the **Modicon TM7** offer: interface blocks (IP 67) for distributed I/O on the CANopen bus [please refer to our website www.schneider-electric.com](http://www.schneider-electric.com)

(1) Standard environment: no particular environmental constraints, operating temperature between + 5°C and + 60°C (+ 41°F and + 140°F), and in fixed installations.

Harsh environment: resistance to hydrocarbons, industrial oils, detergents, solder splashes, relative humidity up to 100%, saline atmosphere, significant temperature variations, operating temperature between - 10°C and + 70°C (+ 14°F and + 158°F), or in mobile installations.

(2) Cordset equipped with a line terminator.

Presentation

The embedded Ethernet communication ports in each Modicon M221, M241 and M251 logic controller and in the Modicon TM4ES4 communication module optimise integration in factory network architectures.

Modicon M221, M241 and M251 controllers can easily be integrated in typical architectures:

- **machine to devices** (variable speed drives, remote I/O modules, operator dialogue terminals) with the I/O Scanner function
- **machine to machine** with the NGVL function
- **machine to supervision** with the Modbus Client/Server function

Ethernet also brings transparency to the factory, in particular - thanks to the firewall functions - making it possible from any point on the network to safely:

- program, monitor a controller or download an application
- access device parameters (variable speed drives for example)

A simple web browser can be used to access machines anytime anywhere, using a tablet or smartphone, for example, using the web servers embedded in Modicon M241 and M251 controllers.

Safety can be enhanced by the use of VPN modems (see our partner programme).

The Modbus TCP/IP protocol

Modbus has been the industry communication standard since 1979.

During the internet revolution, Modbus was combined with Ethernet Modbus/TCP to form Modbus/TCP, a completely open Ethernet protocol. The development of a connection to Modbus/TCP does not require any proprietary component, nor purchase of a licence.

This protocol can easily be combined with any product supporting a standard TCP/IP communication stack.

The specifications can be downloaded free of charge from the following address: www.modbus.org.

Modbus/TCP, simple and open

- The Modbus application layer is simple and universally familiar with its 9 million installed connections.
- Thousands of manufacturers have already implemented this protocol. Many have already developed a Modbus/TCP connection and numerous products are presently available.
- The simplicity of Modbus/TCP enables any fieldbus device, such as an I/O module, to communicate on Ethernet without the need for a powerful microprocessor or a lot of internal memory.

Modbus/TCP, high performance

Thanks to the simplicity of its protocol and the fast speed of 100 Mbps, the performance of Modbus/TCP is excellent. This type of network can therefore be used in realtime applications such as I/O digitisation.

Modbus/TCP, a standard

- The application protocol is identical on Modbus serial link and Modbus/TCP: messages can be routed from one network to the other without converting the protocol.
- Since Modbus operates on the TCP higher layer, users benefit from IP routing, thus enabling devices located anywhere in the world to communicate without worrying about the distance between them.

Modbus and Modbus/TCP are recognised as a fieldbus by the international standard IEC/EN 61158. They also comply with the "national Chinese standard" managed by ITEI.

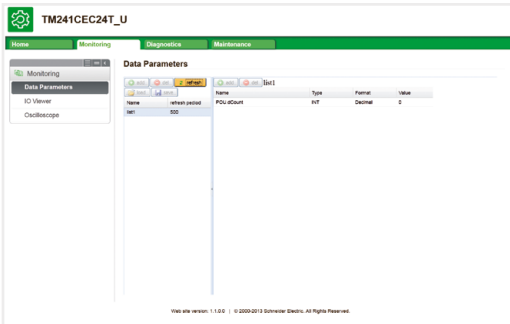

Preconfigured Web server

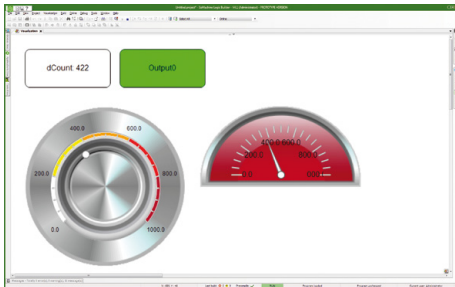

Viewer Web server

Web servers

Preconfigured Web server

Using a simple Internet browser available on PC, smartphone or tablet, this server authorizes the following “ready-to-use” functions:

- With no prior programming
 - Display of the I/O states
 - Controller diagnostics, and of its expansion and communication modules
 - Communication port diagnostics
 - I/O Scanner function diagnostics
 - Maintenance and configuration functions (Ethernet IP, firewall, etc.)
- After configuration
 - Viewing data values
 - Viewing the evolution of those data values over time (oscilloscope function)

Viewer Web server

The SoMachine programming software is used to create customised pages for viewing and monitoring devices. These pages can also be accessed on any mobile device such as a tablet or smartphone with any operating system (iOS, Android, Windows).

Description of Ethernet services

Network Global Variable List (NGVL)

The NGVL protocol allows a controller to share data with other controllers on a local Ethernet network (LAN) or subscribe to data published by other controllers which support the NGVL protocol and thus allowing, for example, synchronisation between control platforms.

I/O Scanner

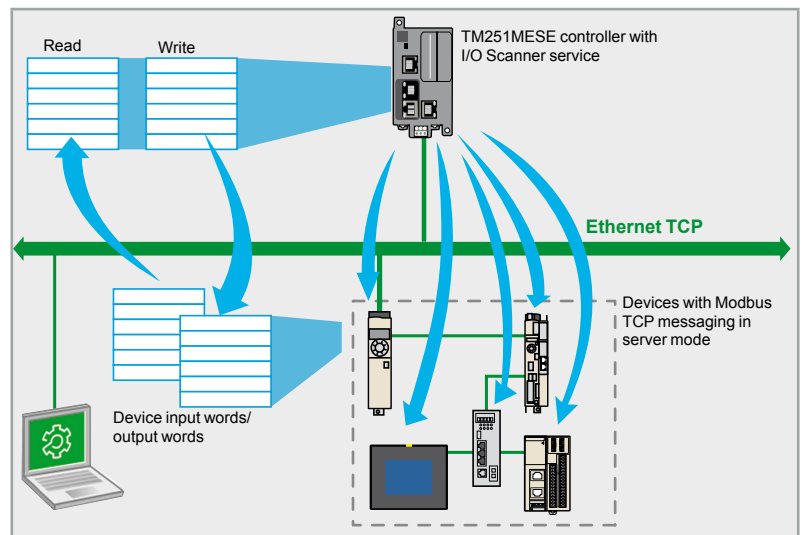

The Modbus TCP I/O Scanner service is used to manage the exchange of remote I/O states on the Ethernet network after a simple configuration operation, with no need for special programming.

I/O Scanner is performed transparently by means of read/write requests in accordance with the Modbus client/server protocol on the TCP profile. This principle of Scanner via a standard protocol enables a device with the I/O Scanner service to communicate with any device supporting Modbus TCP messaging in server mode (slave Modbus TCP). The M251MESE I/O Scanner system supports up to 64 devices (one Modbus request per device).

Description of Ethernet services (continued)

Slave Modbus TCP

This function can be used to create a dedicated I/O table in the controller, which can be accessed via the Modbus TCP protocol and by a controller with the Modbus TCP I/O Scanner function.

Fast Device Replacement (FDR)

This service uses standard address management technologies (BOOTP, DHCP) and the TFTP (Trivial File Transfer Protocol) file management service, in order to simplify maintenance of Ethernet products.

The FDR service is used to replace a device with a new device; the faulty device is detected, reconfigured and automatically rebooted by the system.

Access to files via FTP (File Transfer Protocol)

This service provides access to the controller files from, for example, a PC (FTP client) and is used to exchange files such as application programs, data, etc.

This service can be accessed even if the controller has no application program in its memory.

Dynamic Host Configuration Protocol (DHCP)

This protocol can be used to assign an address to a controller (client DHCP/BOOTP) automatically. This address can be:

- Fixed and determined either in the SoMachine software or included in a post-configuration file
- Assigned by a controller with the DHCP server or BOOTP server function (such as the TM251MESE controller).

SNMP (Simple Network Management Protocol)

From a network management station, the SNMP protocol is used to monitor and control the Ethernet architecture components, meaning problems are diagnosed quickly.

The SNMP protocol is used to access configuration and management objects that are contained in the device MIBs (Management Information Bases).

Modicon M241 and M251 controllers support the "MIB 2 Standard" SNMP network management interface. This interface accesses a first level of network management; it enables the manager to identify the devices making up the architecture and retrieve general information about configuration and operation of the Ethernet Modbus/TCP interfaces.

IP address filter (Whitelisting)

IP addresses that are authorised to access the controller can be loaded in the controller from either an SD card or an FTP client.

Locking communication protocols

Not only SoMachine, NetManage (1), SNMP communication protocols but also Modbus, WEB and FTP servers can be locked individually in the SoMachine software.

(1) The NetManage function can automatically detect which controllers are present on the network. It also offers the option of straightforward connection to any controller present on the network in order to identify it physically by means of a visual or audible message and modify its parameters or manage the resident application.

Transparent Ready class and Functions				
	Logic controllers			
	TM221ME●●● TM221CE●●●	TM241CE●●● TM241C●●● + TM4ES4	TM251MESCC	TM251MESE
Transparent Ready class	A10	B20		
Internet protocol version	IP V4			
Ethernet services				
Programming, downloading, monitoring				
Firmware update	–			
Client and server Modbus TCP				
Slave Modbus TCP				
Ethernet IP (adapter)	–			
Data exchange: NVGL and IEC VAR ACCESS	–			
WEB server	–			
MIB2 SNMP network management	–			
Modbus TCP I/O Scanner	–	–	–	
FTP file transfer	–			
Client DHCP dynamic configuration				
Server DHCP dynamic configuration	–	–	–	
FDR faulty device replacement	–	–	–	
SMS, emails	Availability : 4 th quarter 2014	–	–	–
Safety functions				
IP address filter (Whitelisting)	–			
Locking communication protocols				
Locking IP address routing	–	–	–	

function created

Ethernet ports on logic controllers and the communication module

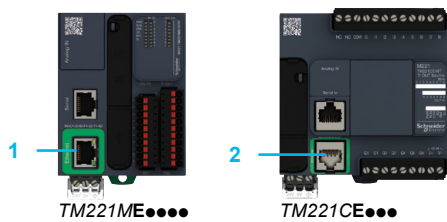

M221 logic controllers

- 1 On **TM221ME●●●●** controllers: RJ 45 connector for Ethernet network, with exchange rate and activity LED.
- 2 On **TM221CE●●●** controllers: RJ 45 connector for Ethernet network, with exchange rate and activity LED.



M241 logic controllers

- 3 On **TM241CE●●●** controllers: RJ 45 connector for Ethernet network, with exchange rate and activity LED.

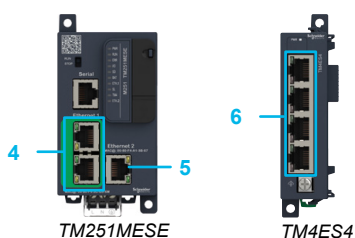

M251 logic controllers

- 4 On **TM251MESE** and **TM251MESCC** controllers: 2 connectors connected by an RJ 45 internal switch for “Machine or Factory” Ethernet network, with exchange rate and activity LED.
- 5 On **TM251MESE** controller: RJ 45 connector for “fieldbus” Ethernet 2 network, with exchange rate and activity LED. The Ethernet 2 network can be used with the Modbus TCP I/O Scanner function.

TM4ES4 Ethernet switch communication module

- 6 4 RJ 45 connectors for Ethernet 2 network, with exchange rate and activity LED.

Communication architecture on Ethernet network

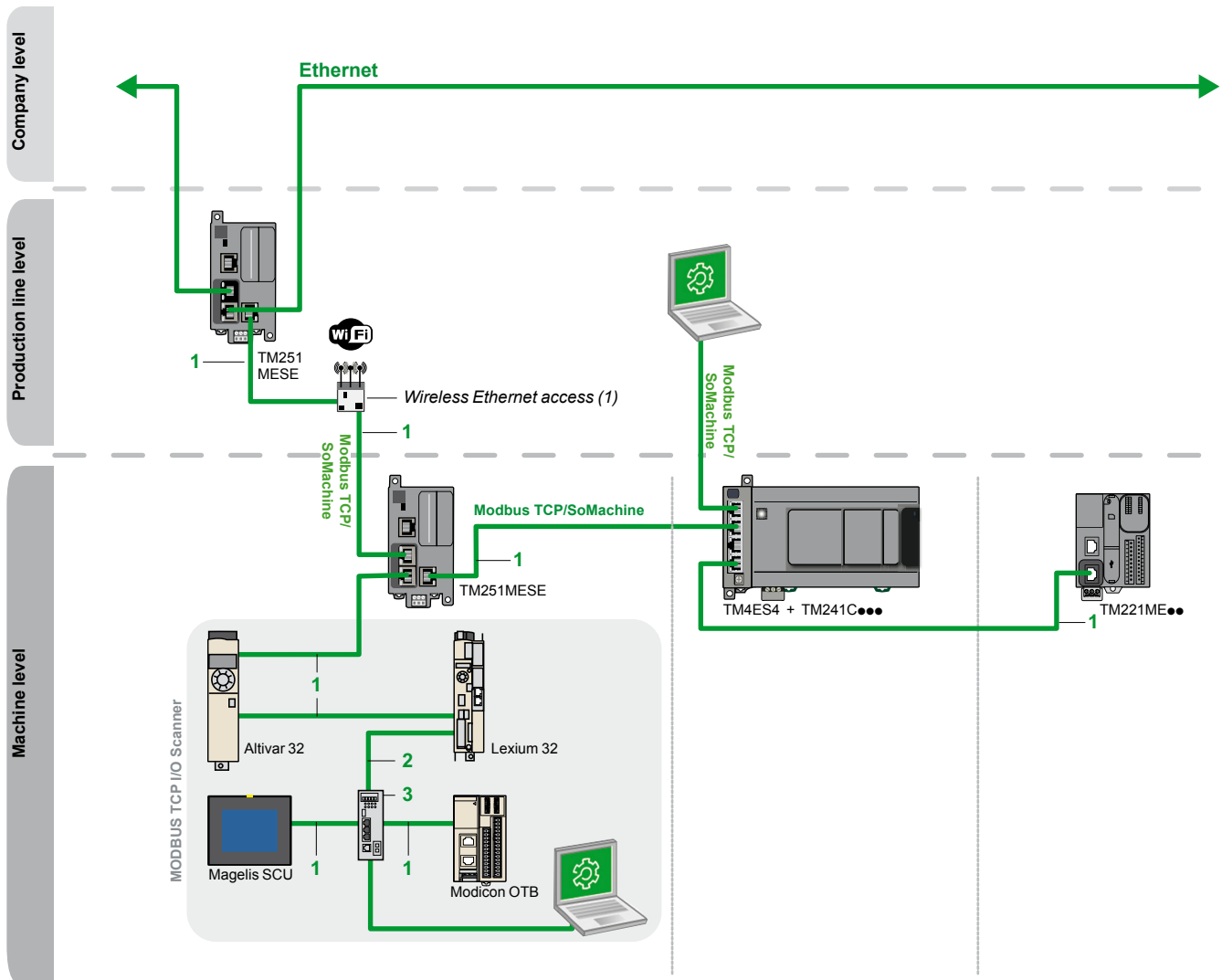

NB: The ports on M251 controllers and the TM4ES4 communication module cannot be used to create redundant architectures.

(1) Wireless Ethernet access, see our partner programme.

Items 1, 2 and 3: see references on next page.

Shielded copper connection cables

ConneXium shielded connection cables are available in two versions to meet the requirements of the various current standards and approvals:

■ EIA/TIA 568 shielded twisted pair cables for CE market

These cables conform to:

- EIA/TIA-568 standard, category CAT 5E
- IEC 11801/EN 50173-1 standard, class D

Their fire resistance conforms to:

- NF C32-070 standard, class C2
- IEC 322/1 standards
- Low Smoke Zero Halogen (LSZH)

■ EIA/TIA 568 shielded twisted pair cables for UL market

These cables are:

- CEC type FT-1
- NEC type CM

A new range of **ConneXium** fully shielded preassembled cables has been specially designed for use in harsh industrial environments. These cables combine a category 5E shielded cable and RJ 45 connectors reinforced with a metal profile.



TCSEC●3M3M●●S4

References

EIA/TIA 568 shielded twisted pair cables for C€ market

Description	End fittings	Item	Type	Length m/ft	Reference	Weight kg/lb
Straight-through copper cables C€ compatible	2 RJ 45 connectors For connection to terminal devices (DTE)	1	standard	2/6.56	490NTW00002	–
				5/16.40	490NTW00005	–
				12/39.37	490NTW00012	–
				40/131.23	490NTW00040	–
				80/262.47	490NTW00080	–
		1	ruggedised	1/3.28	TCSECE3M3M1S4	–
				2/6.56	TCSECE3M3M2S4	–
				3/9.84	TCSECE3M3M3S4	–
				5/16.40	TCSECE3M3M5S4	–
				10/32.81	TCSECE3M3M10S4	–

Shielded twisted pair cables for UL market

Description	End fittings	Item	Type	Length m/ft	Reference	Weight kg/lb
Straight-through copper cables UL compatible	2 RJ 45 connectors For connection to terminal devices (DTE)	1	standard	2/6.56	490NTW00002U	–
				5/16.40	490NTW00005U	–
				12/39.37	490NTW00012U	–
				40/131.23	490NTW00040U	–
				80/262.47	490NTW00080U	–
		1	ruggedised	1/3.28	TCSECU3M3M1S4	–
				2/6.56	TCSECU3M3M2S4	–
				3/9.84	TCSECU3M3M3S4	–
				5/16.40	TCSECU3M3M5S4	–
				10/32.81	TCSECU3M3M10S4	–

Do it Yourself copper cable and connectors

The **ConneXium** “Do it Yourself” offer consists of 2 connector references (M12 and RJ 45) and 1 cable reference - 300 m (984.252 ft) reel - enabling Ethernet 10/100 Mbps network cables to be made up in situ. The maximum length of cables made up in this way is 80 m (262.467 ft.). They are assembled using only a knife and wire cutters (no special tool is required).

Description	Characteristics	Item	Length m/ft	Reference	Weight kg/lb
Ethernet copper cable 2 shielded twisted pairs 24 AWG	Conforms to the standards and approval listed above	2	300/984.25	TCSECN300R2	–
RJ 45 connector	Conforms to EIA/TIA-568-D	2	–	TCSEK3MDS	–

ConneXium unmanaged switches, 3, 4 and 5 ports, twisted pair and optical fibre

Description	Interfaces	Item	Reference	Weight kg/lb
ConneXium unmanaged switches	3 x 10BASE-T/100BASE-TX ports (copper cable), RJ 45 shielded connectors	3	TCSESU033FN0	0.113/ 0.249
	■ 4 x 10BASE-T/100BASE-TX ports (copper cable), RJ 45 shielded connectors ■ 1 x 100BASE-FX port (multimode optical fibre), duplex SC connector	3	TCSESU043F1N0	0.120/ 0.265
	5 x 10BASE-T/100BASE-TX ports (copper cable), RJ 45 shielded connectors	3	TCSESU053FN0	0.113/ 0.249

Other wiring components are available, please consult the **ConneXium** offer on our website www.schneider-electric.com.



TCSESU053FN0

Compatibility		Logic controllers			
Modicon TM2 expansion modules		M221	M221 Book	M241	M251
Digital modules	TM2DDI8DT				
	TM2DDI16DT				
	TM2DDI16DK				
	TM2DDI32DK				
	TM2DAI8DT				
	TM2DDO8UT				
	TM2DDO8TT				
	TM2DDO16UK				
	TM2DDO16TK				
	TM2DDO32UK				
	TM2DDO32TK				
	TM2DRA8RT				
	TM2DRA16RT				
	TM2DMM8DRT				
	TM2DMM24DRF				
Analog modules	TM2AMI2HT				
	TM2AMI2LT				
	TM2AMI4LT				
	TM2AMI8HT				
	TM2ARI8LRJ				
	TM2ARI8LT				
	TM2ARI8HT				
	TM2AMO1HT				
	TM2AVO2HT				
	TM2AMM3HT				
	TM2ALM3LT				
	TM2AMM6HT				
Expert modules (counter modules)	TM200HSC206DT				
	TM200HSC206DF				

- Compatible
- Not compatible

Note: The expansion and communication module range **TWD●●●●●** is not compatible with Modicon M221, M241, M251 logic controller offer.

Configuration

Modicon TM2 digital I/O modules connect to Modicon M221, M221 Book, M241 and M251 logic controllers according to the general rules for the Modicon TM3 system: a maximum of 7 local I/O modules (1); this can be increased to 14 modules (1) using Modicon TM3 bus expansion modules (transmitter and receiver): local I/O + remote I/O.

- The maximum number of Modicon TM2 expansion modules can be reduced by the number of transistor outputs or relay outputs used (see the table below).
- If more transistor or relay outputs are required than the maximum number given in the table, use Modicon TM3 bus expansion modules (transmitter and receiver). In this case, 7 Modicon TM2 modules can be connected to the right of the **TM3XREC1** receiver module without limiting the number of outputs.

Configuration limits	Logic controllers									
	TM221									TM241/ TM251
	C16R	C16T	C24R	C24T	C40R	C40T	M16R ME16R M16RG	M16T ME16T ME16TG	M32TK ME32TK	TM241●●●●● TM251●●●●●
Maximum number of Modicon TM2 module (local) transistor outputs directly connected to the controller (2)	54	67	71	89	113	143	216	(3)		
Maximum number of Modicon TM2 module (local) relay outputs directly connected to the controller (2)	23	29	30	38	48	61	92	98	97	(3)

(1) Excluding TM2●●●24●● and TM2●●●32●● modules: a maximum of 3 local I/O modules and 6 modules in total using TM3 bus expansion modules.
 (2) If using bus expansion modules: maximum number of Modicon TM2 module relay or transistor outputs installed between the controller and the TM3XTRA1 transmitter module (local outputs).
 (3) Up to 7 Modicon TM2 modules regardless of the number of outputs used.

X		TSXCANCBDD03	17
490NTW00002	23	TSXCANCBDD1	17
490NTW00002U	23	TSXCANCBDD3	17
490NTW00005	23	TSXCANCBDD5	17
490NTW00005U	23	TSXCANCD100	17
490NTW00012	23	TSXCANCD300	17
490NTW00012U	23	TSXCANCD50	17
490NTW00040	23	TSXCANKCDF90T	17
490NTW00040U	23	TSXCANKCDF180T	17
490NTW00080	23	TSXCANKCDF90TP	17
490NTW00080U	23	TSXCANTDM4	17
		TSXCSA100	15
B		TSXCSA200	15
BMXCAUSBH018	11	TSXCSA500	15
		TSXSCA50	15
L		TWDXCAFJ010	15
LU9GC3	15	TWDXCAISO	14
		TWDXCAT3RJ	14
T		V	
TCSCAR013M120	17	VW3A8306D30	15
TCSCAR01NM120	17	VW3A8306R03	15
TCSCCN4F3M05T	17	VW3A8306R10	15
TCSCCN4F3M1T	17	VW3A8306R30	15
TCSCCN4F3M3T	17	VW3A8306RC	15
TCCTN023F13M03	17	VW3A8306TF03	15
TCCTN026M16M	17	VW3A8306TF10	15
TCSECE3M3M10S4	23	VW3CANA71	17
TCSECE3M3M1S4	23	VW3CANCARR03	17
TCSECE3M3M2S4	23	VW3CANCARR1	17
TCSECE3M3M3S4	23	VW3CANTAP2	17
TCSECE3M3M5S4	23	VW3M3805R010	17
TCSECN300R2	23	VW3M3805R030	17
TCSECU3M3M10S4	23	X	
TCSECU3M3M1S4	23	XBTZ9008	15
TCSECU3M3M2S4	23	XBTZ938	15
TCSECU3M3M3S4	23	XBTZ9980	15
TCSECU3M3M5S4	23	XBTZ9982	15
TCSEK3MDS	23	XGSZ24	15
TCSESU033FN0	23		
TCSESU043F1N0	23		
TCSESU053FN0	23		
TCSMCN3M4F3C2	15		
TCSMCN3M4M3S2	15		
TCSXCNAMUM3P	11		
TLACDCBA005	17		
TLACDCBA015	17		
TLACDCBA030	17		
TLACDCBA050	17		
TM251MESC	11		
TM251MESE	11		
TM4ES4	13		
TM4PDPS1	13		
TMASD1	11		
TMAT2PSET	11		
TSXCANCA100	17		
TSXCANCA300	17		
TSXCANCA50	17		
TSXCANCADD03	17		
TSXCANCADD1	17		
TSXCANCADD3	17		
TSXCANCADD5	17		
TSXCANCB100	17		
TSXCANCB300	17		
TSXCANCB50	17		

Schneider Electric Industries SAS

Head Office
35, rue Joseph Monier
F-92500 Rueil-Malmaison
France

www.schneider-electric.com

The information provided in this documentation contains general descriptions and/or technical characteristics of the performance of the products contained herein. This documentation is not intended as a substitute for and is not to be used for determining suitability or reliability of these products for specific user applications. It is the duty of any such user or integrator to perform the appropriate and complete risk analysis, evaluation and testing of the products with respect to the relevant specific application or use thereof. Neither Schneider Electric nor any of its affiliates or subsidiaries shall be responsible or liable for misuse of the information contained herein.

Design: Schneider Electric
Photos: Schneider Electric

DIA3ED2140108EN