



# FSV10AR

## Inline Flow Switch for G1" pipe

- General purpose switch for loads of up to 4A inductive
- 0.6 l/min or 3.0 l/min turn on flow rate
- Automatic shut down on flow stop
- Adjustable time delay from 0 to 10 seconds for pump stop
- 1" BSP inline pipe connections



The FSV10AR can be used to control a pump or some other equipment or process via a relay output. If used in a pumped system, the device has to be fitted in the pipe above the pump.

The FSV10AR output relay is energised once the flow rate through the device exceeds 0.6 l/min, or 3 l/min depending on version.

The turn off time delay is adjustable between 0 and 10 seconds.

A flow of less than 0.6 l/min , or 3.0 l/min depending on version, whether due to a lack of supply (e.g. tank empty) or to a decrease in demand(e.g. tap closing), will release the output relay.

Technical Specification			FSV10AR06	FSV10AR30
Flow Tube Material				Brass
Enclosure material				Polyamide
Enclosure rating				IP54
Start up flow rate	Q. min	l/min	0.6	3.0
Max flow rate	Q max	l/min		80
Max Pressure	P max	bar		8
Max Temperature	T max	°C		85
Pipe connections		BSP		1"
Pump stop delay range		sec		0 - 10

Electrical Specification		
Supply Voltage	Vac	24 or 240
Switching Voltage Max	Vac	250
Switching Power Max	kW	1
Switching Current Max	A	10 for resistive load 4A for motor load

Standard Parts	On flow rate	Max Power	Max Pump current
FSV10AR06	0.6l/min	750	4A
FSV10AR30	3.0 l/min	750	4A

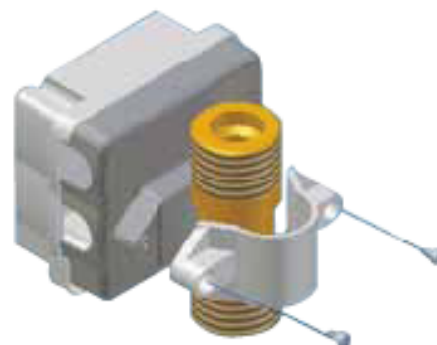
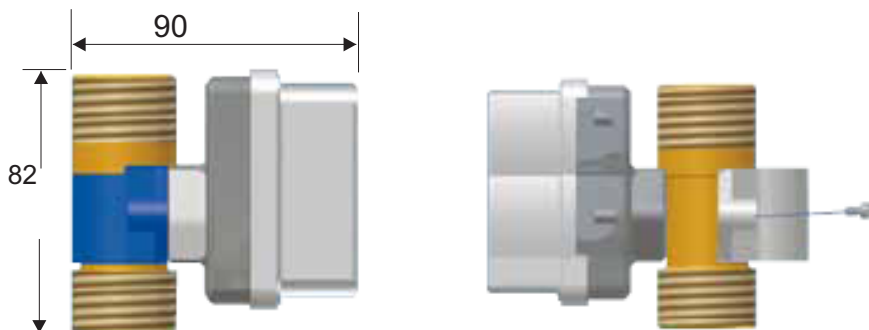

Cynergy3 Components Ltd.  
7 Cobham Road  
Ferndown Industrial Estate  
Wimborne, Dorset BH21 7PE  
Telephone +44 (0) 1202 897969

Email:sales@cynergy3.com

ISO9001 CERTIFIED

www.cynergy3.com



# FSV10AR

## Inline Flow Switch for G1" pipe

### Installation information

The flow switch must be mounted vertically with the flow direction upwards. Pipe connection is G1" (1" BSP). The device relies on the flow of liquid working in opposition to gravity to operate the relay.

The liquid flow moves a plunger inside the brass flow tube, when the flow increases beyond the minimum specified level. A magnet inside the plunger closes a magnetic switch in the control circuit, so causing this to operate the output relay. If the flow drops below the specified level and the plunger has returned to the lower position, the output relay will remain energised for the time delay set and will then be de-energised.

The output relay will also be energised for the time delay set, if the unit is disconnected then reconnected to the supply voltage or the test button is pushed.

The unit can operate on a supply voltage of either 24 or 240Vac.

The output is a SPCO electromechanical relay with contacts rated to 10A(4) A 250Vac.

There is a spare terminal connected to the 240Vac supply that can be used, if a 240Vac supply is being used, to link to the common contact of the relay, if a 240Vac output is required.

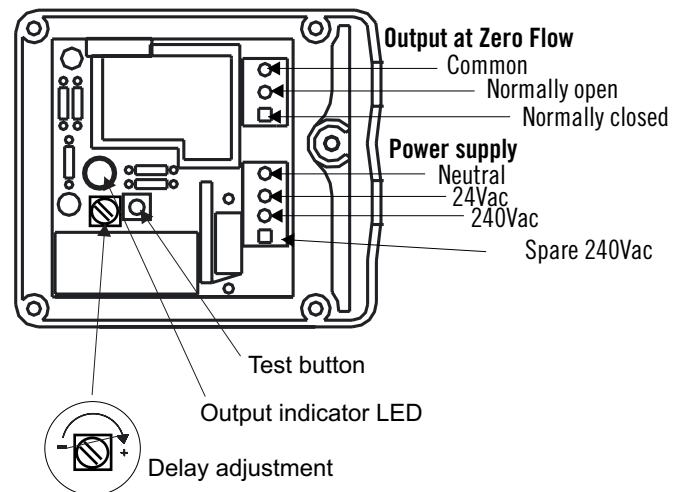
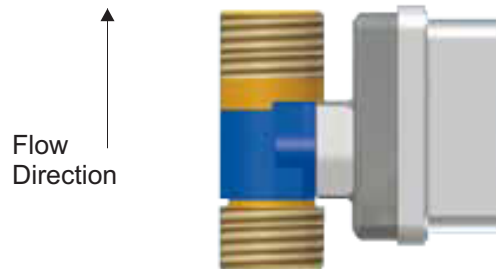

Cynergy3 Components Ltd.  
7 Cobham Road  
Ferndown Industrial Estate  
Wimborne, Dorset BH21 7PE  
Telephone +44 (0) 1202 897969

Email: sales@cynergy3.com

ISO9001 CERTIFIED

www.cynergy3.com