



RS stock numbers : 379-4039, 379-4045



FFSMC Series WRAS APPROVED

Submerged type float switch for reservoir and industrial waste water systems.

This self-weighted cable end float switch is designed for use in turbulent water and water with suspended agglomerates, such as sewer water.

The switch is water resistant up to a depth of 100m, and is insensitive to humidity and condensation, due to the particular design of the switch element. This makes it suitable for applications where there may be wide or rapid fluctuations in ambient or water temperatures. Switching capacity of this new design of self-cleaning switch element is 10A at 250V ac.

The outer casing is manufactured in blow moulded Polyethylene (PEHD) and the switch element is surrounded by non-hygroscopic closed cell expanded polyurethane, hermetically sealing the unit.

The switch is fitted with an internal weight such that it fixes the centre of gravity, and rotation, close to the cable entry. An external counterweight is supplied to adjust the pivot position.

The moulding shape is rounded to prevent the accumulation of solids, that could cause the float to sink.

Technical Specifications

RS stock number		379-4039	379-4045
Cynergy3 part		FFSMC10AW	FFSMC10BW
Contact Form		N/O	N/C
Switching Current Max. Resistive		10 A	
Switching Current Max. Inductive	AC	4A	
	DC	1A	
Power Rating	AC VA	750	
	DC W	180	
Switching Voltage	AC V	250	
	DC V	110	
Cable Material		WRC approved	
Cable length		5m with protective earth wire included	
Body Material		High Density Polyethylene	
Temperature Range	°C	0 / +55	
	°F	+ 32 / +131	
Max. working pressure	bar	10	

It is necessary to use an auxiliary relay, when switching pump motors or any loads that are not purely resistive.



- Operates in Turbulent Fluids
- Unaffected by Suspended Solids
- WRAS approved
- Cable Mounting
- 100m Depth Capability

MECHANICAL

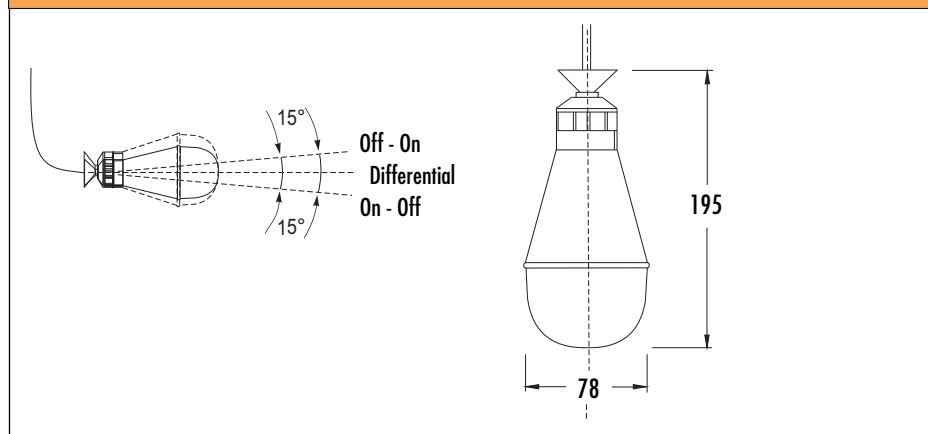

Cynergy3 Components Ltd
7 Cobham Road
Ferndown Industrial Estate
Wimborne
Dorset BH21 7PE
Tel: +44 (0) 1202 897969

sales@cynergy3.com

ISO 9001 CERTIFIED

© 2011 Cynergy3 Components, All Rights Reserved. Specifications are subject to change without prior notice. Cynergy3 Components and the Cynergy3 Components logo are trademarks of Cynergy3 Components Limited.

www.cynergy3.com

Part Numbering System

FFSMC 10 A U 10

Series _____	Cable length in metres: Blank = 5M standard
Max. current _____	Cable covering: Blank = PVC
Contact Form A = n/o B = n/c C = c/o	U = Polyurethane W = WRC approved

Installation

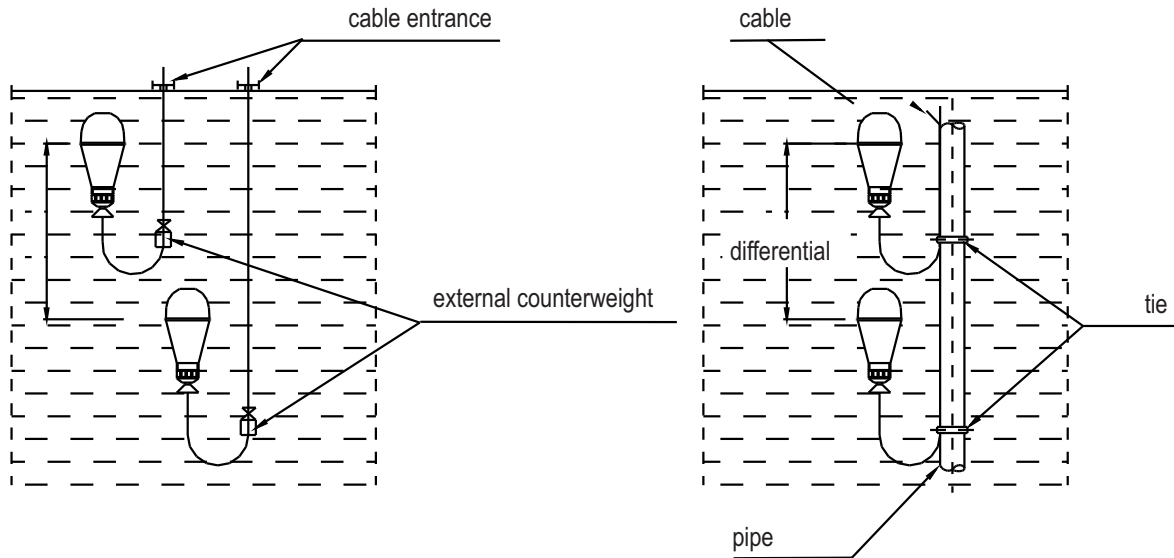

wiring diagram for filling pump

wiring diagram for emptying pump

